

Industrial Engine Attachments Guide



CATERPILLAR®

Table of Contents

Cooling Systems	2
Enclosed Rear Clutch.....	3
Electronics	4-6
Batteries	7
Oil Sumps/Pans.....	8-11
Flywheel Housings	12-15
Air Compressors	16
Air Filtration	17-19
Exhaust Systems.....	20
Alternators	21
Starters	22
Hydraulic Pumps.....	23
Caterpillar Support	24

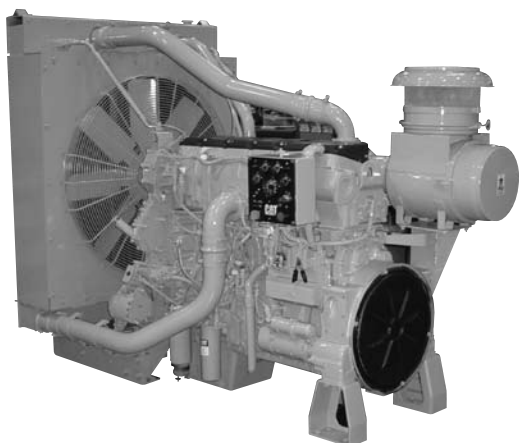

Caterpillar® engine cooling systems are designed to meet the demanding working environments of your equipment. The cooling systems provide side-by-side radiator and ATAAC core with either a suction or blower fan with multiple drive options, air and coolant lines, and all supports and bracing. Fuel coolers and transmission oil coolers are optional on some models.

Cooling Packages for Engines with ACERT™ Technology

Engine Model	Radiator	Fuel Cooler	Transmission Cooler
C7 ACERT	Side by side radiator & ATAAC core		N/A
C9 ACERT	Forward and rear facing turbo exhaust configurations	Attaches to lower front of radiator for suction fan option (available shipped loose)	Engine mounted on RH side
C11 ACERT, C13 ACERT			Provides heat transfer of 49 kW (65 hp)
C15 ACERT, C18 ACERT	Includes air inlet elbow and fan drive mounting		
C27 ACERT, C32 ACERT	Rear exhaust configuration	Available for suction and blower options	N/A

Radiator cooling packages are designed for up to an ambient temperature of 48.9° C (120° F) with a coolant mixture of 50/50 (water/Caterpillar Extended Life Coolant) up to a maximum elevation of 1524 m (5000 ft).

Radiators are factory installed or shipped loose.

N/A — Not Available





A wide range of power take off options are available from Caterpillar. Depending on the pumping application, heavy, medium, and light duty power take offs (PTOs) are available. These PTOs are engineered to match up directly with the engine required for pumping materials —from water for irrigation pumps or sludge for municipalities, to portable pump units to drain a construction work site.

Power Take Offs (Enclosed Rear Clutch)

Engine Model	Type	Output Shaft Diameter — mm (in)	SAE Housing Size
C7 ACERT	Light & Medium	70.4 (2.77)	1, 2
		98.4 (3.87)	
C9 ACERT	Light & Medium	63.5 (2.5)	1,2
		76.2 (2.9)	
	88.9 (3.5)		
C11 ACERT, C13 ACERT	Light & Medium	88.9 (3.5)	1
C15 ACERT, C18 ACERT	Medium	100 (3.94)	0, 1
	Heavy	111 (4.37)	1
C27 ACERT, C32 ACERT	N/A	N/A	N/A

N/A — Not Available

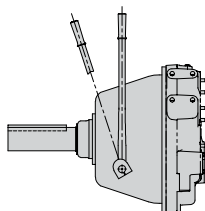

Control Panel



The control panel allows the operator to start and stop the engine, control engine speed, and monitor vital engine information and diagnostics by using electronic analog gauges. The control panel is isolation mounted for exceptional durability. This modular panel can be factory installed and wired or shipped loose for custom installation.

Control Panel

Availability	C7 ACERT, C9 ACERT, C11 ACERT, C13 ACERT, C15 ACERT, C18 ACERT, C27 ACERT, C32 ACERT
Dimensions	
Depth	127 mm (5 in)
Width	255 mm (10 in)
Height	279 mm (11 in)
Weight	6.8 kg (15 lbs)
Features	<ul style="list-style-type: none">• J1939 communication link from ECU to gauges• Oil and fuel pressure gauges• Jacket water temperature gauge• Engine speed and hour meter gauge• Voltmeter gauge• Diagnostic/shutdown lamp• Maintenance clear lamp/switch• Engine speed control switch• Engine start/stop switch/start mag switch• Diagnostic tool connection• Optional J1939 connection (example: Messenger display)• Remote mount capability (up to 10 ft.)• 24 Volt system



Gauge Clusters



Cat® display gauges come from a line of electrical components that are extremely durable. The gauges offer oil and fuel pressure, coolant temperature, engine rpm, hour meter, and voltmeter that are SAE J1939 data compatible. With a proper interface module, up to 12 gauges can be operated simultaneously.

Display Gauges

Availability	C7 ACERT, C9 ACERT, C11 ACERT, C13 ACERT, C15 ACERT, C18 ACERT, C27 ACERT, C32 ACERT
	SAE J1939 Data Link Gauge System
	Operates on 12/24 V electrical systems
	Rugged sealed package design
Features	<ul style="list-style-type: none"> • 2" and 3" gauges available • Oil and fuel pressure • Coolant temperature • Voltmeter • Tachometer and hour meter • Glass lens with anti-fog coating • Integral Deutsch DT 6 Pin connector • Sealed up to 5 psi



Cat® Messenger Display Unit



The **Messenger** operator information dashboard display provides real-time, visual feedback on engine or machine operating conditions to help ensure the best performance possible from an engine or machine. Messenger uses a full graphics information display with transfective LCD technology. Multiple communication data links can be utilized to provide real-time performance and operating information while the vehicle is in use. The information can be displayed in either multilingual text (even graphical languages) or a graphical format.

Messenger

Availability	C7 ACERT, C9 ACERT, C11 ACERT, C13 ACERT, C15 ACERT, C18 ACERT, C27 ACERT, C32 ACERT
Status	Able to view: <ul style="list-style-type: none"> • Pressures, temperatures, and speeds • Engine load factor • Fuel economy • Desired engine speed • Estimated fuel rate • Vehicle speed limit
Diagnostic	Quickly access active fault codes
Lifetime and Trip	Review the lifetime totals for: <ul style="list-style-type: none"> • Fuel economy • Distance • Average speed • Fuel consumption • Engine hours
Maintenance	Easily track your oil change preventive maintenance intervals
Theft Deterrent	Protect your vehicle from theft when idling or shutdown

Caterpillar Premium High Output (PHO) Batteries



All Caterpillar machines and generator sets exclusively use Caterpillar Premium High Output Batteries that are designed to meet the requirements needed in rugged environments. There are several benefits for using Caterpillar batteries:

- Superior vibration resistance comes from rugged plates, connectors, and element anchoring.
- All-weather performance — extra-heavy grids provide more life and more power in extreme cold and extreme heat.
- Less maintenance is needed because extra corrosion resistance and overcharge protection are built in.
- Readily accepts charge — when battery is completely discharged — due to optimal acid/paste mixture.
- Protection against “shorts” and vibration damage with microporous polyethylene separators.
- Damaging spills avoided with 45° tilt capability.
- Reduced possibility of explosion from external sparks provided by flame arrestor safety vents.
- Extra strength — especially in sub-zero temperatures — with impact-resistant cases.

The PHO batteries available as an option with your industrial engines come in three different 12 volt options (shipped dry):

Options for Caterpillar PHO Batteries**

	Option 1	Option 2	Option 3
Cold cranking amps for 30 seconds at -18°C (0° F)	1300	1000	950
Reserve capacity minutes — minimum of 25 amp output at 27° C (80° F)	400	275	170
Amp. hr. capacity @ 20 hours	190	140	90
Construction	Note 1*	Note 1*	Note 2*
BCI Group Size	4D	4D	31
Length — mm (in)	527 (20.75)	527 (20.75)	328.4 (12.9)
Width — mm (in)	218 (8.58)	218 (8.58)	171.2 (6.74)
Height — mm (in)	248 (9.76)	248 (9.76)	240.3 (9.46)
Weight (wet) — kg (lb)	54 (119)	46 (101)	27 (60)
Weight (dry) — kg (lb)	37 (81)	27 (59)	20 (44)
Nominal acid to fill — L (qt)	14.0 (14.8)	15.0 (15.9)	6.2 (6.6)

*Note 1: Low maintenance (1000 hr.) hybrid: lead-antimony and lead calcium grids. Accessible vent caps.

*Note 2: Maintenance free design: lead-calcium grids. Recessed accessible vent caps if maintenance checks required.

**Availability: C7 ACERT, C9 ACERT, C11 ACERT, C13 ACERT, C15 ACERT, C18 ACERT, C27 ACERT, C32 ACERT



Rear Sump/Pan

Caterpillar offers a variety of oil pans to meet various types of engine installation requirements. The oil sumps come in front, rear, and center configurations. The sizes of the oil pans range from 18 L (4.8 gal) for smaller displacement engines up to 106 L (28 gal) for the larger displacement engines with all engines offering a right- or left-hand oil level gauge location.

Oil Sumps/Pans and Dipstick Location Options

Engine Model	Oil Sump/Pan Type	Dipstick Locations	Drain Location
C7 ACERT	Front/Rear	LH or RH Mounted	LH
C7 ACERT	Front/Rear	LH or RH Mounted	LH
C7 ACERT	Center	LH or RH Mounted	RH or LH
C9 ACERT	Front/Rear	LH or RH Mounted	RH and LH
C9 ACERT	Center	LH or RH Mounted	RH and LH
C11 ACERT, C13 ACERT	Front/Rear	LH or RH Mounted	RH and LH

*Volume refers to service refill with new oil filter change

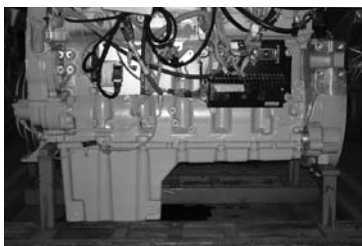

Front Sump/Pan



Center Sump/Pan

Volume*	Dimensions
25 L (6.6 gal)	<ul style="list-style-type: none"> • 280 mm (11.02 in) below crankshaft center line to bottom of pan
18 L (4.8 gal)	<ul style="list-style-type: none"> • 272.1 mm (10.71 in) from center line of crank to oil drain • 297.7 mm (11.72 in) from center line of crank to bottom of oil pan
25 L (6.6 gal)	<ul style="list-style-type: none"> • 267.5 mm (10.5 in) from center line of crank to oil drain • 284.5 mm (11.2 in) from center line of crank to bottom of oil pan
31 L (8.2 gal)	<ul style="list-style-type: none"> • 359.7 mm (14.16 in) from center line of crank to oil drain • 380.7 mm (14.99 in) from center line of crank to bottom of oil pan
31 L (8.2 gal)	<ul style="list-style-type: none"> • 283.7 mm (11.17 in) from center line of crank to oil drain • 298.7 mm (11.76 in) from center line of crank to bottom of oil pan
37 L (9.8 gal)	<ul style="list-style-type: none"> • 434.5 mm (17.11 in) from center line of crank to oil drain • 459.5 mm (18.09 in) from center line of crank to bottom of oil pan

Oil Sumps/Pans and Dipstick Location Options (cont)

Engine Model	Oil Sump/Pan Type	Dipstick Locations	Drain Location
C11 ACERT, C13 ACERT	Center	LH or RH Mounted	RH and LH
C11 ACERT, C13 ACERT	Front/Rear	LH or RH Mounted	RH and LH
C15 ACERT, C18 ACERT	Center	LH or RH Mounted	RH and LH
C15 ACERT, C18 ACERT	Center	LH or RH Mounted	RH and LH
C15 ACERT, C18 ACERT	Front/Rear	LH or RH Mounted	RH and LH
C27 ACERT, C32 ACERT	Rear	LH or RH Mounted	RH and LH
C27 ACERT, C32 ACERT	Center	LH or RH Mounted	RH and LH

*Volume refers to service refill with new oil filter change



Volume*	Dimensions
31 L (8.2 gal)	<ul style="list-style-type: none"> • 267 mm (10.51 in) from center line of crank to oil drain • 292 mm (11.5 in) from center line of crank to bottom of oil pan
31 L (8.2 gal)	<ul style="list-style-type: none"> • 377.5 mm (14.9 in) from center line of crank to oil drain • 402.5 mm (15.8 in) from center line of crank to bottom of oil pan
69 L (18.2 gal)	<ul style="list-style-type: none"> • 398.1 mm (15.67 in) from center line of crank to oil drain • 423.1 mm (16.66 in) from center line of crank to bottom of oil pan
61 L (16.1 gal)	<ul style="list-style-type: none"> • 443.8 mm (17.5 in) from center line of crank to oil drain • 472.3 mm (18.6 in) from center line of crank to bottom of oil pan
34 L (9 gal)	<ul style="list-style-type: none"> • 412.3 mm (16.23 in) from center line of crank to oil drain • 423.3 mm (16.67 in) from center line of crank to oil drain • 448.3 mm (17.65 in) from center line of crank to bottom of oil pan
74 L (19.5 gal)	<ul style="list-style-type: none"> • 393.0 mm (15.47 in) from center line of crank to oil drain • 433.6 mm (17.07 in) from center line of crank to bottom of oil pan
106 L (28 gal)	<ul style="list-style-type: none"> • 548 mm (21.6 in) from center line of crank to bottom of oil pan



Flywheel Housings



Standard Housing

Caterpillar offers a variety of different flywheel housings from SAE No. 0 through No. 3 in aluminum or cast iron configurations. There are flywheel adapters to match Clark Torque Converters and Transmissions, Allison Transmissions, Dana Spicer Clutches, or Funk Drive Components. Also offered are Rear Power Take Offs with spline shafts that can drive Dana couplings, and various SAE A through C drive hydraulic pumps or other components.

Flywheel Housings for Engines with ACERT™ Technology

Engine Model	SAE Size	Material	Starter Mount Location
C7 ACERT	1	Cast Iron	RH
C7 ACERT	2	Cast Iron	RH and/or LH
C7 ACERT	3	Cast Iron	RH
C7 ACERT	2	Cast Iron	LH
C9 ACERT, C11 ACERT, C13 ACERT	1	Aluminum	LH
C9 ACERT, C11 ACERT, C13 ACERT, C15 ACERT, C18 ACERT	1	Cast Iron	RH and/or LH
C9 ACERT, C11 ACERT, C13 ACERT	1	Cast Iron	RH and/or LH

N/A — Not Available



**Hydraulic Pump Drive Housing
(2 O'clock Position)**



**Hydraulic Pump Drive Housing
(10 & 2 O'clock Position)**

Hydraulic Drive and PTO Position and Size	Drive and PTO Torque Capability
N/A	N/A
N/A	N/A
N/A	N/A
Rear facing 23 tooth involute spline shaft at 1 o'clock position (standard)	514 N•m (379 lb-ft)
N/A	N/A
N/A	N/A
Rear facing drives at 10 and 2 o'clock positions. Any combination of SAE "B" and/or "C" drives; 2 or 4 bolt mounting flange	180 N•m (133 lb-ft) for SAE "B" 580 N•m (428 lb-ft) for SAE "C" drives

Flywheel Housings (cont)

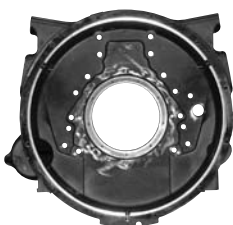

Standard Housing

Flywheel Housings for Engines with ACERT™ Technology

Engine Model	SAE Size	Material	Starter Mount Location
C11 ACERT, C13 ACERT	1	Aluminum	LH
C15 ACERT, C18 ACERT	0	Cast Iron	RH and/or LH
C15 ACERT, C18 ACERT	1	Cast Iron	LH
C15 ACERT, C18 ACERT	1	Cast Iron	LH
C15 ACERT, C18 ACERT	1	Cast Iron	LH
C15 ACERT, C18 ACERT	1	Cast Iron	LH
C15 ACERT, C18 ACERT	1	Cast Iron	LH
C15 ACERT, C18 ACERT	1	Cast Iron	LH
C27 ACERT, C32 ACERT	1	Cast Iron	RH and/or LH
C27 ACERT, C32 ACERT	0	Cast Iron	RH and/or LH

N/A — Not Available



**Hydraulic Pump Drive Housing
(2 O'clock Position)**



**Hydraulic Pump Drive Housing
(10 & 2 O'clock Position)**

y (cont)

Hydraulic Drive and PTO Position and Size	Drive and PTO Torque Capability
Rear facing 23 tooth involute spline shaft at 1 o'clock position	339 N•m (250 lb-ft)
N/A	N/A
Rear facing SAE "C" drive at 1 o'clock position; 2 bolt mounting flange	500 N•m (369 lb-ft)
Rear facing SAE "B" drive at 10 and 2 o'clock positions; 2 or 4 bolt mounting flange	180 N•m (133 lb-ft) for each position. Total: 360 N•m (266 lb-ft)
Rear facing SAE "C" drive at 10 and 2 o'clock positions; 2 or 4 bolt mounting flange	554 N•m (409 lb-ft) at 10 o'clock 516 N•m (381 lb-ft) at 2 o'clock positions. Total: 1070 N•m (789 lb-ft)
Rear facing SAE "B" drive at 10 o'clock and SAE "C" drive at 2 o'clock positions; 2 or 4 bolt mounting flange	180 N•m (133 lb-ft) at 10 o'clock 516 N•m (381 lb-ft) at 2 o'clock positions. Total: 696 N•m (514 lb-ft)
Rear facing SAE "C" drive at 10 o'clock and SAE "B" drive at 2 o'clock positions; 2 or 4 bolt mounting flange	554 N•m (409 lb-ft) at 10 o'clock 180 N•m (133 lb-ft) at 2 o'clock positions. Total: 734 N•m (542 lb-ft)
Two rear facing drives at 10 and 2 o'clock positions. Any combination of SAE "A," "B" and/or "C" drives; 2 bolt mounting flange	55 N•m (41 lb-ft) for SAE "A" 180 N•m (133 lb-ft) for SAE "B" drives 360 N•m (265 lb-ft) for SAE "C" drives Total: 360 N•m (265 lb-ft)
Two rear facing drives at 10 and 2 o'clock positions. Any combination of SAE "A" and/or "B" drives; 2 bolt mounting flange	55 N•m (41 lb-ft) for SAE "A" 180 N•m (133 lb-ft) for SAE "B" drives
Two rear facing drives at 10 and 2 o'clock positions. Any combination of SAE "C," "D," and/or "E" with "F" spline drives.	580 N•m (428 lb-ft) for SAE "C" 1669 N•m (1231 lb-ft) for SAE "D" and "E" 2652 N•m (1956 lb-ft) for SAE "E" with "F" spline.

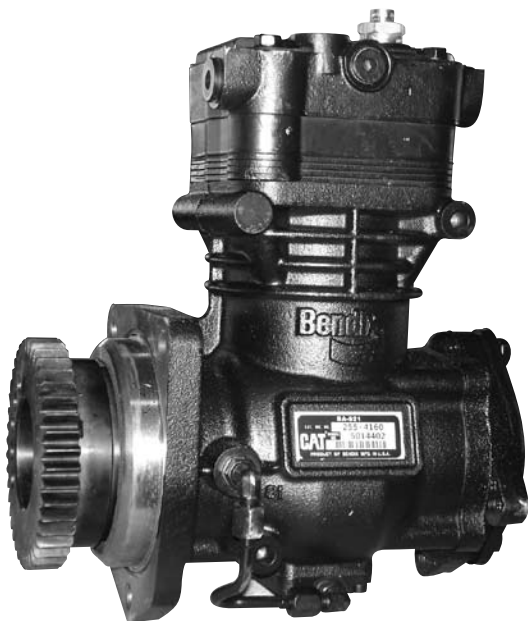

Caterpillar offers an extensive line of rugged and durable engine mounted air compressors to meet your equipment needs. Air compressors range in air flow from 374 L/min (13.2 cfm) up to 889 L/min (31.4 cfm).

Air Compressors for Engines with ACERT™ Technology

Engine Model	Air Flow	Miscellaneous
C7 ACERT, C9 ACERT	374 L/min (13.2 cfm) @ 1250 rpm	Two cylinder, gear drive, single stage design with SAE "A" hydraulic pump drive with a 2 bolt mounting flange. Maximum torque: 60 N•m (44 lb-ft)
C7 ACERT, C9 ACERT	467 L/min (16.5 cfm) @ 1250 rpm	Two cylinder, gear drive, single stage design with SAE "A" hydraulic pump drive with a 2 bolt mounting flange. Maximum torque: 60 N•m (44 lb-ft)
C11 ACERT, C13 ACERT, C15 ACERT, C18 ACERT	445 L/min (15.7 cfm) @ 1250 rpm	Single cylinder, gear drive, swept displacement design
C11 ACERT, C13 ACERT, C15 ACERT, C18 ACERT	889 L/min (31.4 cfm) @ 1250 rpm	Two cylinder, gear drive, swept displacement design
C27 ACERT, C32 ACERT	N/A	N/A

N/A — Not Available

Cat Turbine Pre-Cleaners

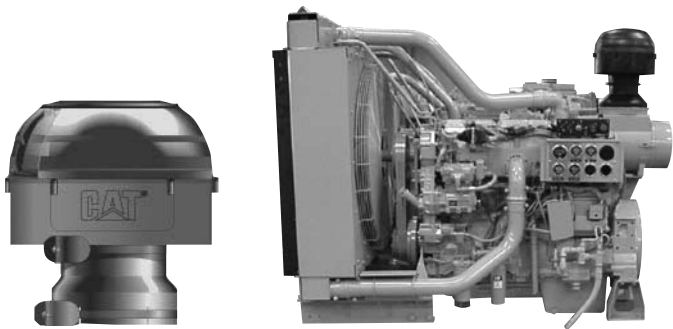

Contaminants like dust, leaves, wood chips, sand, and snow can severely limit air filter life. A Cat Turbine PreCleaner expels all types of particles in any weather condition to better protect your air intake system.

The Cat Turbine PreCleaner:

- Increases air filter life by as much as 700%
- Improves fuel economy
- Enhances performance
- Extends engine life
- Lowers maintenance costs
- Reduces downtime

The PreCleaner design improves the efficiency and aerodynamics of the system:

Cat Turbine PreCleaners*

Feature	Benefit
Straked, recessed vanes	Direct particles out toward inner wall
Curved particle accelerator	Reduces turbulence, increases particle ejection
Dome shape	Offers smooth air transition
Top-suspended particle accelerator	Causes bearings to spin more freely
Inner wall strakes	Help trap and eject particles

*Availability: C7 ACERT, C9 ACERT, C11 ACERT, C13 ACERT, C15 ACERT, C18 ACERT, C27 ACERT, C32 ACERT

Air Filters



Cat radial seal air filters offer terrific value, with standard filter elements for normal duty and ultra-high efficiency elements for extremely dusty and high soot conditions.

A. Radial Seal Design*

No tools are required so service times and maintenance costs are minimized.

B. All Steel Adapter Ring*

Most new Cat machines leave the factory with radial seal air filters installed. Older machines can be easily converted with this adapter. It quickly bolts into position to accept the new filter design.

C. One-Piece Molded Urethane End Caps*

Forms a tough, reliable, corrosion-proof bond to paper media. Up to 30% more seal contact area for a seal that is more reliable than conventional elements.

D. Densely Pleated Filter Paper*

Large media area provides superior capacity without impeding airflow.

E. Built-In Pleat Support and Positive Pleat Spacing*

Prevents pleat bunching and ensures optimum filter media surface area.

F. Heavy-Duty Metal Inner and Outer Wrap*

Increases structural strength and durability.

G. Baked-On Enamel Outer Filter Wrap*

Creates a corrosion-resistant filter wrap.

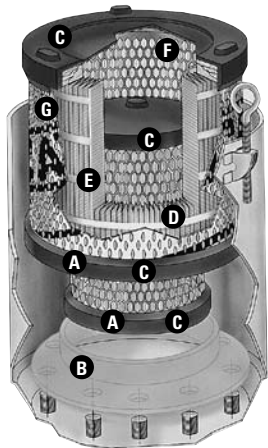

*Availability: C7 ACERT, C9 ACERT, C11 ACERT, C13 ACERT, C15 ACERT, C18 ACERT, C27 ACERT, C32 ACERT

Air Filter Availability

	C7 ACERT	C9 ACERT	C11 ACERT	C13 ACERT	C15 ACERT	C18 ACERT	C27 ACERT	C32 ACERT
Single Turbo Configuration	√	√	√	√	√	√	√	√
Twin Turbo Configuration						√	√	√

Air Filter Service Indicator



Clean filter element.



As the filter element fills with dust and soot, the indicator moves up the calibrated gauge to show the exact percentage of filter life remaining.



Filter is no longer allowing sufficient air into the engine and must be changed.

Since it is not possible to visually determine when a filter reaches capacity, changing air filters too soon can result in unnecessary labor and filter costs. Conversely, in highly contaminated air, you may need to change filters earlier than scheduled to ensure full airflow and engine power.

The Cat air filter service indicator:

- Shows how much filter life remains and ensures optimum engine performance
- Is accurate and easy to read
- Minimizes filter changes, reducing filter costs
- Indicates airflow resistance even when the machine is not running
- Can be reset with the spring-release button

A Cat air filter service indicator can often save eight filter changes when in a cleaner environment for 6,000 operating hours:

Limit Filter Changes and Save Money*

	Number of Changes	
	Without Indicator**	With Indicator
Primary Filter	24	18
Secondary Filter	8	6
Total	32	24

*Availability: C7 ACERT, C9 ACERT, C11 ACERT, C13 ACERT, C15 ACERT, C18 ACERT, C27 ACERT, C32 ACERT

**When changing the primary element at 250 operating hours and the secondary element at 750 operating hours.

Exhaust Systems



A number of exhaust systems are available for Caterpillar engines. The engines are able to accommodate rear and forward facing exhausts with flexible fittings and adapters to match up to the muffler required. The various components are engineered to withstand harsh environments through extensive vibration and material testing.



Exhaust Systems for Engines with ACERT™ Technology*

	C7 ACERT, C9 ACERT	C11 ACERT, C13 ACERT	C15 ACERT, C18 ACERT	C27 ACERT, C32 ACERT
Muffler	<ul style="list-style-type: none"> • Std. muffler; 127 mm (5 in.) inlet • Oval design • Mount horiz. or vertical 	<ul style="list-style-type: none"> • Std. muffler; 127 mm (5 in.) inlet • Oval design • Mount horiz. or vertical 	<ul style="list-style-type: none"> • Spark arr. muffler; 203 mm (8 in.) inlet • Spark arr. muffler; 254 mm (10 in.) inlet — C18 ACERT Only 	<ul style="list-style-type: none"> • Std. muffler; 127 mm (5 in.) inlet • Oval design • Vertical installation
Muffler Supports	<ul style="list-style-type: none"> • Spark arr. muffler; 152 mm (6 in.) inlet 	<ul style="list-style-type: none"> • Support muffler (exhaust elbow) 	<ul style="list-style-type: none"> • Support muffler (exhaust elbow) 	<ul style="list-style-type: none"> • Support muffler
Adapters	<ul style="list-style-type: none"> • 127 mm (5 in.) diam; weldable* 	<ul style="list-style-type: none"> • 127 mm (5 in.) diam; weldable* 	<ul style="list-style-type: none"> • 127 mm (5 in.), 152 mm (6 in.), 203 mm (8 in.) diam; weldable* 	N/A
<i>Straight exhaust adapters are available for all models</i>				
Flex Fittings	<ul style="list-style-type: none"> • 127 mm (5 in.) diameter; 457 mm (18 in.) length 	<ul style="list-style-type: none"> • 127 mm (5 in.) diameter; 457 mm (18 in.) length 	<ul style="list-style-type: none"> • 127 mm (5 in.) diameter; 457 mm (18 in.) length • 203 mm (8 in.) diameter; 305 mm (12 in.) length • 152 mm (6 in.) diameter; 588 mm (24 in.) length 	N/A
Front or Rear Facing Exhaust	Yes	Yes	Yes	Yes
Miscellaneous	<ul style="list-style-type: none"> • Rain cap; 126 mm (5 in.) diam. 	<ul style="list-style-type: none"> • Rain cap; 126 mm or 152 mm (5 in. or 6 in.) diam. 	<ul style="list-style-type: none"> • Rain cap; 126 mm, 152 mm, or 171 mm (5, 6, or 6.75 in.) diam. 	<ul style="list-style-type: none"> • Rain cap; 126 mm (5 in.) diam.

*90 degree elbows only

N/A — Not Available



- 1** Built-in electronic voltage regulators
- 2** High-efficiency cooling system
- 3** Brushless design for harsh environments

Extra heavy duty, heavy duty, and medium duty alternators are matched to your engine for

optimum performance as 12V or 24V options with amperages ranging from 50 to 150 amps. To reduce maintenance requirements, select alternator models are equipped with debris guards and brushless rotating components.

Alternators for Engines with ACERT™ Technology

Engine Model	Voltage/Amps	Miscellaneous
C7 ACERT, C9 ACERT, C11 ACERT, C13 ACERT	12V/60 Amp	<ul style="list-style-type: none"> • Heavy duty brushless with integral regulator • Rotation either CW or CCW • Not equipped with debris guard
C27 ACERT, C32 ACERT	12V/85 Amp	<ul style="list-style-type: none"> • Extra heavy duty brushless with integral regulator • Rotation either CW or CCW
C7 ACERT, C9 ACERT, C11 ACERT, C13 ACERT, C15 ACERT, C18 ACERT	12V/115 Amp	<ul style="list-style-type: none"> • Medium duty brush type with integral regulator • Rotation either CW or CCW
C7 ACERT, C9 ACERT, C11 ACERT, C13 ACERT	12V/145 Amp	<ul style="list-style-type: none"> • Medium duty brush type with integral regulator • Rotation CW from end of pulley • Equipped with debris guard
C7 ACERT, C9 ACERT, C11 ACERT, C13 ACERT, C15 ACERT, C18 ACERT	24V/50 Amp	<ul style="list-style-type: none"> • Heavy duty brushless with integral regulator • Rotation either CW or CCW • Not equipped with debris guard
C7 ACERT, C9 ACERT, C11 ACERT, C13 ACERT, C15 ACERT, C18 ACERT, C27 ACERT, C32 ACERT	24V/60 Amp	<ul style="list-style-type: none"> • Heavy duty brushless with integral regulator • Rotation either CW or CCW
C7 ACERT, C9 ACERT, C11 ACERT, C13 ACERT	24V/65 Amp	<ul style="list-style-type: none"> • Heavy duty brushless with integral regulator • Rotation CW from end of pulley • Not equipped with debris guard
C7 ACERT, C9 ACERT, C11 ACERT, C13 ACERT, C15 ACERT, C18 ACERT, C27 ACERT, C32 ACERT	24V/80 Amp	<ul style="list-style-type: none"> • Heavy duty brushless with integral regulator • Rotation CW from end of pulley • Not equipped with debris guard
C7 ACERT, C9 ACERT, C11 ACERT, C13 ACERT, C15 ACERT, C18 ACERT, C27 ACERT, C32 ACERT	24V/95 Amp	<ul style="list-style-type: none"> • Heavy duty brushless with integral regulator • Rotation CW from end of pulley • Not equipped with debris guard
C27 ACERT, C32 ACERT	24V/150 Amp	<ul style="list-style-type: none"> • Heavy duty brushless with integral regulator • Rotation either CW or CCW • Equipped with debris guard

All models equipped for dual belt drive.

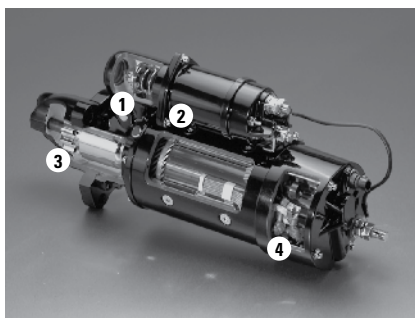

- 1** Positive-engagement shift mechanism ensures precise pinion-to-ring gear engagement.
- 2** Seamless one-piece solenoid case protects against corrosion.
- 3** Rotatable drive housing allows flexible mounting.
- 4** Brush holder provides constant spring pressure for even wear.

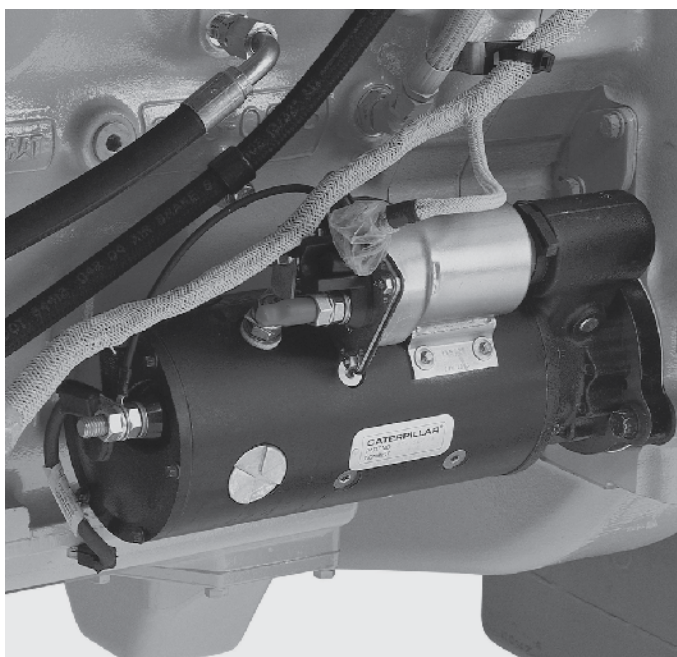

Electric starters are available as 12V or 24V for all engine models as dual or single configurations. Air starters are available for select engine models in applications where they are required.

Starters for Engines with ACERT™ Technology

Engine Model	Electric	Air	Mounting
C7 ACERT, C9 ACERT, C11 ACERT, C13 ACERT	12V	N/A	RH and/or LH
C7 ACERT, C9 ACERT, C11 ACERT, C13 ACERT	24V	N/A	RH and/or LH
C15 ACERT, C18 ACERT	12V	Yes	RH and/or LH
C15 ACERT, C18 ACERT	24V	Yes	RH and/or LH
C27 ACERT, C32 ACERT	24V	N/A	RH and/or LH

N/A — Not Available

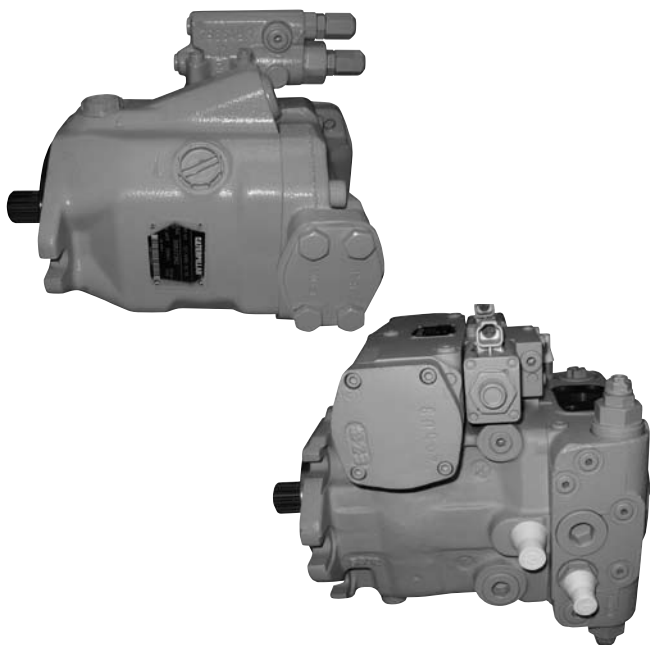

Caterpillar offers a variety of hydraulic pump types and sizes that are matched to the pump drives available on Caterpillar engines. Fixed displacement gear pumps are available in three sizes for basic requirements. Variable displacement piston pumps with load sensing controls are available in two sizes for use in circuits with closed center valves where energy conservation is a priority. Hydrostatic pumps, typically used for propel applications, are available in two displacements.

Hydraulic Pumps for Engines with ACERT™ Technology

Engine Model	25 cc Gear @ 207 bar	29 cc Gear @ 207 bar	33 cc Gear @ 207 bar	45 cc Piston @ 241 bar	55 cc Piston @ 241 bar	71 cc Hydrostatic @ 350 bar	100 cc Hydrostatic @ 350 bar
C7 ACERT	52	61	69	N/A	N/A	N/A	N/A
C9 ACERT	52	61	69	94 or 124*	151	195	275
C11ACERT/ C13 ACERT	60	70	79	107	151	195	275
C15 ACERT/ C18 ACERT	63	73	83	113 or 124*	151	195	275
C27 ACERT/ C32 ACERT	52	61	69	94	N/A	N/A	N/A

Theoretical Flow (lpm) @ 2100 Engine rpm

*Dependent upon pump drive location



Cat Dealer Network

The reputation of Caterpillar as a quality supplier of engines has been built on our long commitment to service and support. No other engine manufacturer can boast of the worldwide dealer network and parts distribution system that Caterpillar customers have come to rely on. Repowers, new engine installation, specialized engine arrangements for pumping applications — whatever you need, wherever and whenever you need it, your Cat dealer can provide it. From scheduled maintenance programs to parts and service support, diagnostics and emergency response — the Caterpillar dealer network stands ready with the expertise, technology, and parts to keep you up and running at peak efficiency.

Customer Support Agreement (CSA)

A CSA is a partnership between you and your Cat dealer to provide preventive maintenance and service. It is tailored to fit your business needs and can range from simple Preventive Maintenance Kits to sophisticated Total Cost Performance Guarantees. The flexible, individualized plans give you access to trained experts who know your Cat engine, maximizing productivity and minimizing costs. With a CSA, your Cat dealer can provide service in a more timely, convenient, efficient, and cost-effective manner.

Caterpillar Extended Service Coverage (ESC)

Your Cat dealer offers protection past the standard warranty period, including protection against unexpected repair bills, 100 percent parts and labor reimbursement for covered components, service at any Cat dealer or authorized repair facility within the covered territory, and a variety of coverage terms. The initial owner may purchase ESC up to one year after taking delivery of the engine. Coverage is available for up to five years, with various hour increments available for most applications and models.

New Warranty for Industrial Engines with ACERT Technology

Proven performance has prompted Caterpillar to extend warranty coverage for industrial engines equipped with ACERT Technology. The warranty period is 24 months or 3,000 hours, whichever comes first, with the first 12 months at unlimited hours. A third year of warranty covers five major components: cylinder block casting, cylinder head casting, crankshaft (excluding bearings), camshaft, and connecting rods. For details on other diesel or gas engine warranties, contact your local Cat dealer.

Caterpillar. Your Local Resource. Worldwide.

Your Cat dealer is prepared to answer any questions you may have about Cat Power Systems, customer support, parts or service capability anywhere in the world. For the name and number of the Cat dealer nearest you, visit our website or contact Caterpillar Inc. World Headquarters in Peoria, Illinois, U.S.A.

World Headquarters:

Caterpillar Inc.

Peoria, Illinois, U.S.A

Tel: (309) 578-6298

Fax: (309) 578-2559

Mailing Address:

Caterpillar Inc.

Industrial Power Systems

P.O. Box 610

Mossville, IL 61552

www.cat-industrial.com

E-mail: cat_power@cat.com

Materials and specifications are subject to change without notice. Rating ranges listed include the lowest and highest available for a specific engine or family of engines. Load factor and time at rated load and speed will determine the best engine/rating match.

LEDH6161-02 (2-08)

©2008 Caterpillar

All rights reserved.

CAT, CATERPILLAR, their respective logos, ACERT, "Caterpillar Yellow" and the POWER EDGE trade dress, as well as corporate and product identity used herein are trademarks of Caterpillar and may not be used without permission.

CATERPILLAR®
TODAY'S WORK. TOMORROW'S WORLD.™