

Irrigation Engine Ratings Guide

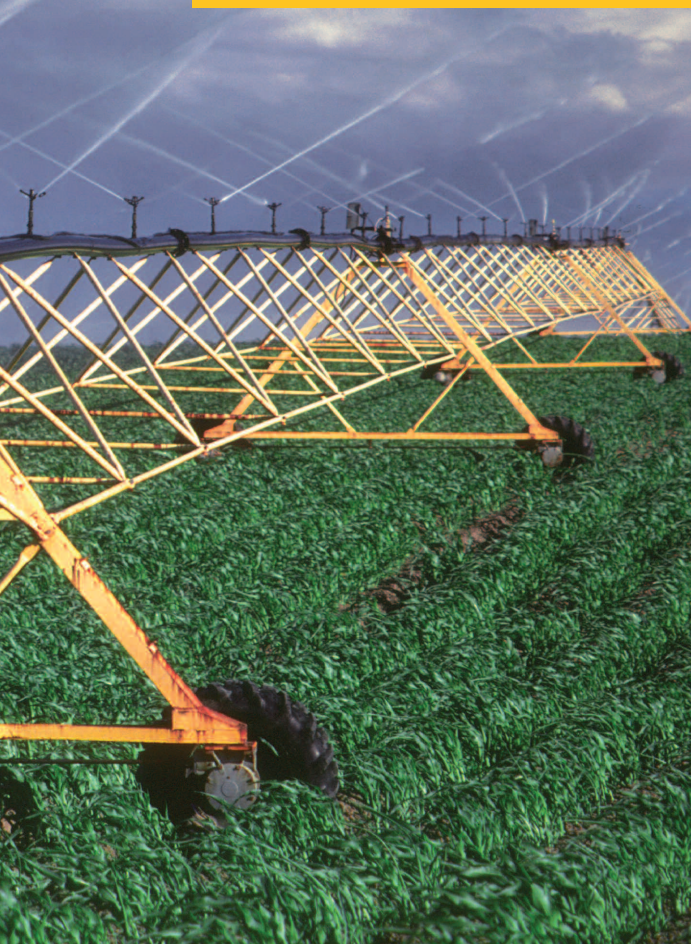

CATERPILLAR®

Table of Contents

Rating Conditions	1
ISO 9001:2000 Certification	1
EPA Stationary Regulations	1
Abbreviations	1
Caterpillar® Engines	2-3
Power Estimator	4-7
Diesel Engines	
Tier 1/Stage I Ratings	8
Tier 2/Stage II Ratings	9-10
Tier 3/Stage IIIA Ratings	11
Gas Engines	12-14
Dealer Service	15
Rating Power Ranges	16
EPA & EU Non-Road Emissions Regulations	16

Rating Conditions

Diesel Engines — up to 6.6 liter

All rating conditions are based on ISO/TR14396, inlet air standard conditions with a total barometric pressure of 100 kPa (29.5 in. Hg), with a vapor pressure of 1 kPa (.295 in. Hg), and 25°C (77°F). Performance measured using fuel to specification EPA 2D 89.330-96 with a density of 0.845-0.850 kg/L @ 15° C (59° F) and fuel inlet temperature 40° C (104° F).

Diesel Engines — 7 liter and higher

All rating conditions are based on SAE J1995, inlet air standard conditions of 99 kPa (29.31 in. Hg) dry barometer and 25°C (77°F) temperature. Performance measured using a standard fuel with fuel gravity of 35° API having a lower heating value of 42,780 kJ/kg (18,390 btu/lb) when used at 29° C (84.2° F) with a density of 838.9 g/L.

Gas Engines

Ratings are based on SAE J1349 standard conditions of 100 kPa (29.61 in Hg) and 25° C (77° F). These ratings also apply at ISO3046, DIN6271, and BS5514 standard conditions of 100 kPa (29.61 in Hg) and 27° C (81° F); and API 7B-11C standard conditions of 99 kPa (29.28 in Hg) and 29° C (85° F) also apply.

Ratings are based on dry natural gas having an LHV of 35.54 MJ/Nm³ (905 btu/ft³). Variations in altitude, temperature, and gas composition from standard conditions may require a reduction in engine horsepower.

Turbocharged-Aftercooled ratings apply to 1525 m (5000 ft) and 25°C (77°F).

ISO 9001:2000 Certification

Factory-designed systems built at Caterpillar ISO 9001:2000 certified facilities.

EPA Stationary Regulations

For important information related to the New Source Performance Standard (NSPS) for diesel stationary engines, refer to the EPA web site at www.epa.gov.

Abbreviations

NA	Naturally Aspirated
T	Turbocharged
TA	Turbocharged/Aftercooled
ATAAC	Air-to-Air Aftercooled
bhp	Brake horsepower
bkW	Brake Kilowatts
IOPU	Industrial Open Power Unit
LCR	Low Compression Ratio
HCR	High Compression Ratio
LE	Low Emission
STD	Standard (Stoichiometric) Engine highest power rating
CAT	Standard (Stoichiometric) Engine catalystrating



Compare the Total Cost of Cat® Diesel and Natural Gas Engine Power...

Look at irrigation power sources and you're likely to find that Caterpillar® engines deliver one of the lowest lifetime costs compared to other diesel or natural gas stationary engines, utility electric power, automotive gasoline, or natural-gas-conversion engines. Before you choose, it pays to compare.

...To Other Engine Brands

Cat® engines are built for long, hard, trouble-free days in the field. They're proven to deliver reliable operation, high fuel economy, and world-class emissions. Intelligent design means long service intervals and simple maintenance that minimizes downtime. Both diesel and gas engines incorporate the most advanced engine technologies for performance no one else can match.

Cat diesel engines are built with high-strength components for thousands of operating hours before overhaul. For emissions, Cat diesels set the standard. You can choose units that comply with U.S. EPA Tier 1/Stage I, Tier 2/Stage II, and Tier 3/Stage IIIA regulations. ACERT™ Technology, the latest diesel innovation, precisely shapes combustion to maintain performance and efficiency while dramatically reducing emissions. It also provides a foundation for the next level of emission regulations.

Cat gas engines combine the same robust components with innovative combustion design and advanced control systems that automatically and precisely regulate major engine functions for optimum fuel economy and stringent emissions reduction. Emissions comply with U.S. EPA, California Air Resources Board (CARB) and European Union standards. Cat engines can be customized with remote communications, sound-attenuated and weather-protective enclosures, fuel tank bases, silencers, starting aids, cooling options, and other accessories.

...To Electric Power

At first glance, all-electric systems may seem attractive. But if your site isn't near existing power lines, installation costs can be extreme — often more than the price of a Cat engine. Long-term costs run high, too. To get affordable rates, you might have to sign a long-term contract that allows the utility to interrupt or limit your power at any time. So when it's hot and dry and electricity demand soars — just when your crops need water most — your irrigation system could be idle.

Whether natural gas or diesel, a Cat engine ensures irrigating power whenever you need it — and often costs less to operate. You'll spend quite a bit less for maintenance than for utility bills and maintenance of power lines, motors, controls, and transformers. And when it's time to upgrade or repower, your Cat engine has high resale value. If you find electric pumping and drive systems are best for your operation, consider Caterpillar package generator sets — fast and easy to install, affordable, and reliable.

...To Automotive Engines

Gasoline or natural-gas-conversion automotive engines look economical at first: buy them cheap, and when they wear out, scrap them and buy new ones. But in the long run, you'll pay a premium. And don't forget durability — you could be on your third or fourth automotive engine before a Cat engine is ready for overhaul.

Count on Your Cat Dealer

A critical reason to choose Cat engines is the support you get from the Cat dealer network, the world's finest service organization with more than 1,800 locations. Wherever you are, your dealer is there to help you select, install, operate, and service your Cat diesel or gas engines. The parts and supplies you need are close by and in stock for fast delivery. Your dealer can provide a service and maintenance package to fit your needs — so you can focus on your crops. Caterpillar also offers flexible leases and other financing plans to make your project affordable.

For Top Irrigation System Efficiency...

This selection guide will help you identify your irrigation power needs and choose the right Cat engine to meet those needs efficiently. High reliability and low lifetime cost often make Cat engine power your most attractive option.

First, follow these 12 steps to calculate the flywheel power your irrigation system requires. Then match your results to the selection charts on the following pages to see which Cat engine offers the best efficiency and economy.

Determine Total Dynamic Pumping Head

1. Static Head

Vertical distance pump must lift water from *pickup point to discharge*.

Pickup point is the draw-down water level in the well or the surface of stream or pond from which water is pumped.

Discharge level, in the case of a pivot or traveling system, is height of the sprinkler at highest point in the field.

2. Pressure Head

For open discharge to pond or canal, pressure head = 0.

For sprinkler system a fair initial estimate is 415 kPa (60 psi). Actual value varies from 275 kPa (40 psi) for a low pressure system to about 550 kPa (80 psi) for a high pressure system. Multiply kPa x 0.102 to get meters pressure head (psi pressure x 2.31 = ft. pressure head).

3. Friction Head

Estimate 1 m (ft) friction head per 100 m (ft) pipe run from pickup point to start of sprinkler system or to open discharge. Actual value based on pipe selection, bends, fittings.

4 Total Dynamic Pumping Head

Total of 1, 2, and 3.

Centrifugal Pump taking water from pond to open discharge

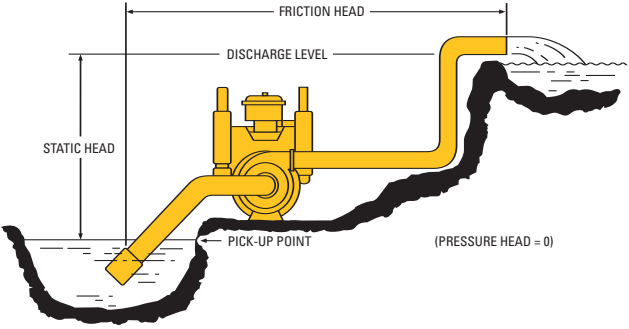

Preliminary Estimate

Final Calculation

_____ m
ft

_____ m
ft

_____ m
ft

_____ m
ft

_____ m
ft

_____ m
ft

_____ m
ft

_____ m
ft

Deep Well Pump delivering to sprinkler system

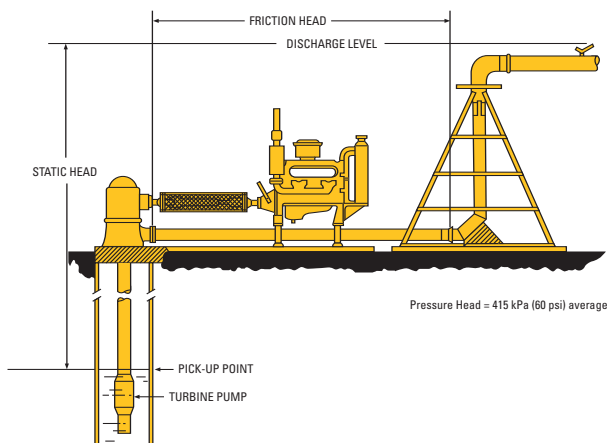

Calculate Power to Deliver Needed Water Flow

5. Flow Rate Required

Will vary for crop, soil, terrain, and climate. To deliver 8.5 mm (1/3 in) per day to a quarter section [65 ha (160 acre)] field, estimate 63.5 L/s (1006 gpm).

6. Calculate Water Power Requirement

Power to pump required water, if pump and drive were 100% efficient.

$$\text{kW} = \frac{\text{Flow Rate (5)} \times \text{Total Dynamic Pumping Head (4)}}{102}$$

$$\text{hp} = \frac{\text{Flow Rate (5)} \times \text{Total Dynamic Pumping Head (4)}}{3,960}$$

7. Pump Efficiency

For preliminary estimate use 0.75.

8. Drive Efficiency

For direct-driven centrifugal pump use 1.0. For right angle drive use 0.95.

9. Calculate Pumping Power Requirements

$$\frac{\text{kW}}{\text{hp}} = \frac{\text{kW (hp) (6)}}{\text{Pump Eff. (7)} \times \text{Drive Eff. (8)}}$$

10. Power to Drive Pivot or Traveling System

For pivot system, estimate 1.1 engine kW (1.5 hp) per tower. Irrigation system supplier will quote power for electric, hydraulic, or other drive.

11. Power for Engine Accessories and Cooling

For preliminary use, estimate 5% of engine kW or hp. Your Cat Engine supplier can provide this data; varies with engine speed, altitude, and climate.

12. Total Engine Flywheel Power

Sum of 9, 10, and 11.

Preliminary Estimate

Final Calculation

_____ L/s
gpm

_____ L/s
gpm

_____ kW
hp

_____ kW
hp

_____ kW
hp

_____ kW
hp

_____ kW
hp

_____ kW
hp

_____ kW
hp

_____ kW
hp

_____ kW
hp

_____ kW
hp

3406C

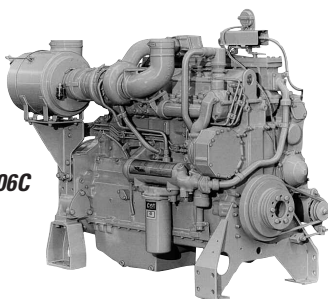

TIER 1/STAGE I RATINGS

	1800 rpm		2000 rpm	
	bkW (bhp)	l/hr (gal/hr)	bkW (bhp)	l/hr (gal/hr)
3406C	242-287 (325-385)	57.8-70.9 (15.3-18.7)	242-328 (325-440)	63.2-83.3 (16.7-22.0)

	1800 rpm		1800-2100 rpm	
	bkW (bhp)	l/hr (gal/hr)	bkW (bhp)	l/hr (gal/hr)
3508B	746 (1000)	182.5 (48.2)		
3512B	1119 (1500)	278.6 (73.6)		
3516B	1492 (2000)	380.1 (100.4)		

Tier 1 refers to EPA (U.S.) requirements. Stage I refers to European requirements.

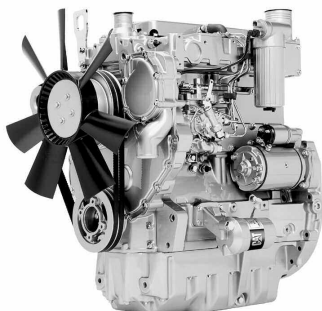

3054C

TIER 2/STAGE II RATINGS

	2800 rpm		3000 rpm	
	bkW (bhp)	l/hr (gal/hr)	bkW (bhp)	l/hr (gal/hr)
C1.1 NA	14.8	5.9	15.6	6.5
IOPU	(19.8)	(1.6)	(20.9)	(1.7)
C1.5 NA	20.8	7.6	21.1	7.9
IOPU	(27.9)	(2.0)	(28.3)	(2.1)
C2.2 NA	31.7	11.1	32.2	11.5
IOPU	(42.5)	(2.9)	(43.2)	(3.0)

	2200 rpm		2400 rpm	
	bkW (bhp)	l/hr (gal/hr)	bkW (bhp)	l/hr (gal/hr)
3054C NA			62	14.8
IOPU			(83.1)	(3.9)
3054C T†	72.5	18.3		
IOPU	(97.2)	(4.8)		
3054C†*	95	—		
IOPU	(127.4)	—		

*ATAAC

† The power taken for driven equipment must not exceed 85% of the ratings shown. The engine speed should not exceed 2200 rpm. Consult your dealer for complete details.

Tier 2 refers to EPA (U.S.) requirements. Stage II refers to European requirements.

C32 ACERT

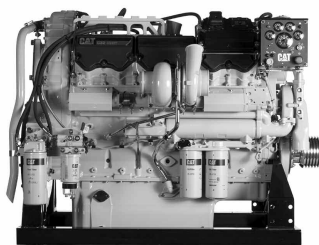

TIER 2 RATINGS

	1800-2100 rpm	
	bkW (bhp)	l/hr (gal/hr)
C27	597-652	141.6-160.9
ACERT*	(800-875)	(37.4-42.5)
C32	709	172.6-180.2
ACERT*	(950)	(45.6-47.6)

*ATAAC

Tier 2 refers to EPA (U.S.) requirements.

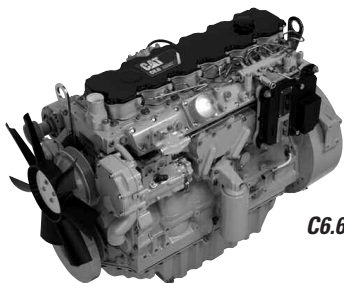

C6.6 ACERT

TIER 3/STAGE IIIA RATINGS

	2200 rpm		3000 rpm		3000 rpm	
	bkW (bhp)	l/hr (gal/hr)	bkW (bhp)	l/hr (gal/hr)	bkW (bhp)	l/hr (gal/hr)
C1.1 NA* IOPU			14.8 (19.8)	5.9 (1.6)	15.6 (20.9)	6.5 (1.7)
C1.5 NA* IOPU			20.8 (27.9)	7.6 (2.0)	21.1 (28.3)	7.9 (2.1)
C2.2 NA* IOPU			31.7 (42.5)	11.1 (2.9)	32.2 (43.2)	11.5 (3.0)
C2.2 T* IOPU			34.3 (46.0)	13.8 (3.6)		
C4.4 ACERT** IOPU	96.5 (129.0)	— —				

	1800 rpm		2200 rpm	
	bkW (bhp)	l/hr (gal/hr)	bkW (bhp)	l/hr (gal/hr)
C6.6 ACERT** IOPU	151 (202)	32.1 (8.5)	129.5 & 151 (173.5 & 202)	30.8 & 35 (8.1 & 9.2)

	1800-2100 rpm		1800-2200 rpm	
	bkW (bhp)	l/hr (gal/hr)	bkW (bhp)	l/hr (gal/hr)
C7 ACERT			168 (225)	44.7-46.6 (11.8-12.3)
C9 ACERT			205-224 (275-300)	53.0-60.2 (14.0-15.9)
C11 ACERT	242-261 (325-350)	63.7-72.3 (16.8-19.1)		
C13 ACERT	287-309 (385-415)	72.0-79.9 (19.0-21.2)		
C15 ACERT	328-354 (440-475)	84.8-95.4 (22.4-25.2)		
C18 ACERT	428-447 (575-600)	108.3-121.5 (28.6-32.1)		

*Available 2nd half, 2007

**The power taken for driven equipment must not exceed 80% of the ratings shown. The fuel consumption quoted is based on this load factor. The engine speed should not exceed 2200 rpm. Consult your dealer for complete details.

Tier 3 refers to EPA (U.S.) requirements. Stage IIIA refers to European requirements.

G3306

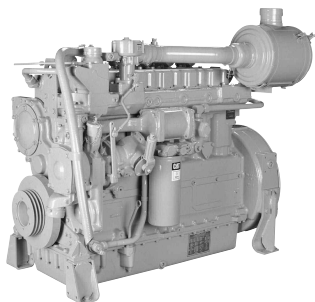

ENGINE RATINGS

	Engine Config.	1400 rpm		1600 rpm		1800 rpm	
		bkW (bhp)	m ³ /hr (ft ³ /hr)	bkW (bhp)	m ³ /hr (ft ³ /hr)	bkW (bhp)	m ³ /hr (ft ³ /hr)
G3304	STD/	55	18.2	65	21.1	71	22.7
NA HCR	CAT	(74)	(641)	(87)	(744)	(95)	(802)

	Engine Config.	1800 rpm	
		bkW (bhp)	m ³ /hr (ft ³ /hr)
G3306	STD/	108	34.2
NA HCR	CAT	(145)	(1209)
G3306	STD/	112-164	37.3-51.4
TA HCR	CAT	(150-220)	(1319-1815)
G3306	STD/	151-157	50.0-52.0
TA LCR	CAT	(203-211)	(1767-1836)

	Engine Config.	1400 rpm		1800 rpm	
		bkW (bhp)	m ³ /hr (ft ³ /hr)	bkW (bhp)	m ³ /hr (ft ³ /hr)
G3406	STD/	131	—	160	53.5
NA HCR	CAT	(176)	—	(215)	(1900)
G3406	STD/	187-209	56.9-62.7		
TA HCR	CAT	(250-280)	(2011-2215)		
G3406	STD/	187-206	56.8-64.3		
TA LCR	CAT	(250-276)	(2005-2271)		
G3406	STD			242-257	75.5-77.5
TA HCR				(325-345)	(2668-2738)
G3406	STD			242-272	72.3-80.4
TA LCR				(325-365)	(2552-2841)
G3406	CAT			206-218	64.3-67.9
TA LCR				(276-292)	(2272-2398)

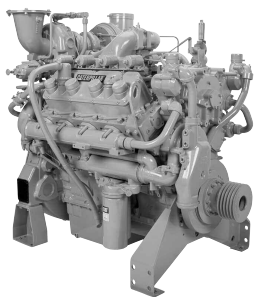

G3408

ENGINE RATINGS

	Engine Config.	1400 rpm		1800 rpm	
		bkW (bhp)	m ³ /hr (ft ³ /hr)	bkW (bhp)	m ³ /hr (ft ³ /hr)
G3408 NA HCR	STD/ CAT	157 (210)	49 (1738)	190 (255)	60 (2118)
G3408 TA HCR	STD/ CAT	261 (350)	79.0 (2791)		
G3408 TA LCR	STD/ CAT	223 (300)	70.9 (2505)		
G3408 TA HCR	STD			298-336 (400-450)	93.9-103.7 (3331-3680)
G3408 TA LCR	STD			298-336 (400-450)	88.0-99.5 (3127-3514)
G3408 TA HCR	CAT	231 (310)	72.0 (2542)	302 (405)	94.6 (3360)
G3408 TA HCR	LE			317 (425)	93.0 (3301)

	Engine Config.	1400 rpm		1800 rpm	
		bkW (bhp)	m ³ /hr (ft ³ /hr)	bkW (bhp)	m ³ /hr (ft ³ /hr)
G3412 NA HCR	STD/ CAT	235 (315)	72.0 (2544)	272 (365)	89.7 (3167)
G3412 TA HCR	STD/ CAT	347 (465)	111.2 (3926)		
G3412 TA LCR	STD/ CAT	335-369 (450-495)	105.9-120.7 (3739-4264)		
G3412 TA HCR	STD			448-503 (600-675)	144.0-151.7 (5113-5387)
G3412 TA LCR	STD			448-503 (600-675)	136.4-149.1 (4842-5266)
G3412 TA HCR	CAT			453 (607)	141.5 (4997)
G3412C TA HCR	LE			475 (637)	147.2 (5224)
G3412C TA HCR	LE			475 (637)	150.0 (5309)

G3512

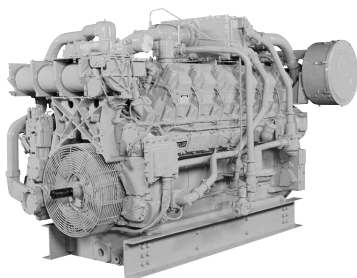

ENGINE RATINGS

	Engine Config.	1200 rpm		1400 rpm	
		bkW (bhp)	m ³ /hr (ft ³ /hr)	bkW (bhp)	m ³ /hr (ft ³ /hr)
G3508 NA HCR	STD/ CAT	231 (310)	75.5 (2666)		
G3508 TA HCR	STD/ CAT	392-406 (526-545)	123.1-127.3 (5346-4495)		
G3508 TA LCR	LE			472-500 (633-670)	151.0-162.7 (5332-5746)

	Engine Config.	1200 rpm		1400 rpm	
		bkW (bhp)	m ³ /hr (ft ³ /hr)	bkW (bhp)	m ³ /hr (ft ³ /hr)
G3512 NA HCR	STD/ CAT	391 (524)	128.2 (4526)		
G3512 TA HCR	STD/ CAT	589-607 (790-814)	184.4-190.0 (6547-6713)		
G3512 TA LCR	LE	604-641 (810-860)	186.7-199.9 (6629-7096)	705-749 (945-1004)	222.7-231.1 (7905-8208)

	Engine Config.	1200 rpm		1400 rpm	
		bkW (bhp)	m ³ /hr (ft ³ /hr)	bkW (bhp)	m ³ /hr (ft ³ /hr)
G3516 NA HCR	STD/ CAT	492 (660)	161.9 (5747)		
G3516 TA HCR	STD/ CAT	783 (1050)	251.7 (8934)		
G3516 TA LCR	LE	809-858 (1085-1150)	251.6-265.6 (8932-9430)	943-999 (1265-1340)	297.3-314.7 (10556-11173)



Cat Dealer Network

The reputation of Caterpillar as a quality supplier of engines has been built on our long commitment to service and support. No other engine manufacturer can boast of the worldwide dealer network and parts distribution system that Caterpillar customers have come to rely on. Repowers, new engine installation, specialized engine arrangements for pumping applications — whatever you need, wherever and whenever you need it, your Cat dealer can provide it. From scheduled maintenance programs to parts and service support, diagnostics and emergency response — the Caterpillar dealer network stands ready with the expertise, technology, and parts to keep you up and running at peak efficiency.

Customer Support Agreement (CSA)

A CSA is a partnership between you and your Cat dealer to provide preventive maintenance and service. It is tailored to fit your business needs and can range from simple Preventive Maintenance Kits to sophisticated Total Cost Performance Guarantees. The flexible, individualized plans give you access to trained experts who know your Cat engine, maximizing productivity and minimizing costs. With a CSA, your Cat dealer can provide service in a more timely, convenient, efficient, and cost-effective manner.

Caterpillar Extended Service Coverage (ESC)

Your Cat dealer offers protection past the standard warranty period, including protection against unexpected repair bills, 100 percent parts and labor reimbursement for covered components, service at any Cat dealer or authorized repair facility within the covered territory, and a variety of coverage terms. The initial owner may purchase ESC up to one year after taking delivery of the engine. Coverage is available for up to five years, with various hour increments available for most applications and models.

New Warranty for Industrial Engines with ACERT™ Technology

Proven performance has prompted Caterpillar to extend warranty coverage for industrial engines equipped with ACERT™ Technology. The warranty period is 24 months or 3,000 hours, whichever comes first, with the first 12 months at unlimited hours. A third year of warranty covers five major components: cylinder block casting, cylinder head casting, crankshaft (excluding bearings), camshaft, and connecting rods. For details on other diesel or gas engine warranties, contact your local Cat dealer.

Additional Industrial Diesel Engine Ratings

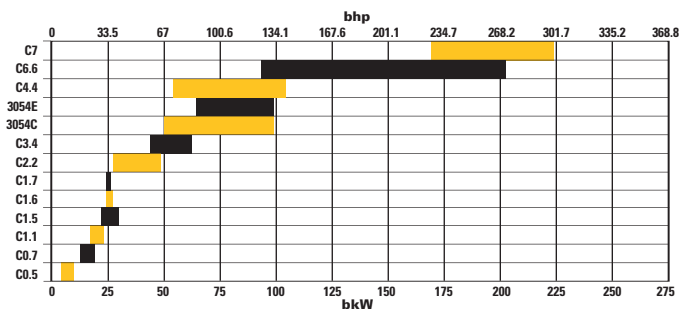
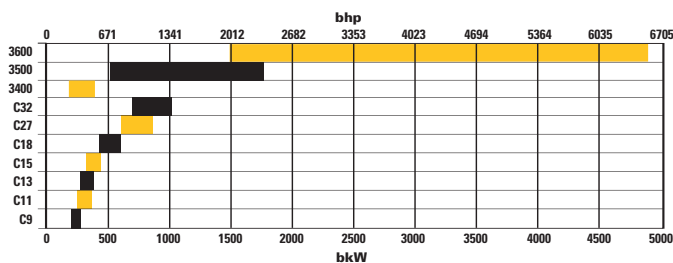

EPA & EU Non-Road Emissions Regulations* Tier 3 Changes for Consent Decree Signatories

U.S. EPA Non-road

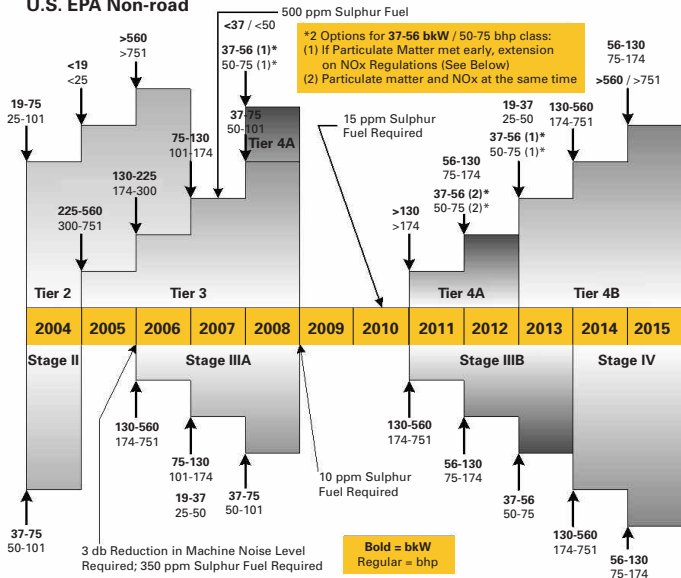

European Non-road

*Additional information available at www.dieselnets.com

Caterpillar. Your Local Resource. Worldwide.

Your Cat dealer is prepared to answer any questions you may have about Cat Power Systems, customer support, parts or service capability anywhere in the world. For the name and number of the Cat dealer nearest you, visit our website or contact Caterpillar Inc. World Headquarters in Peoria, Illinois, U.S.A.

World Headquarters:

Caterpillar Inc.

Peoria, Illinois, U.S.A

Tel: (309) 578-6298

Fax: (309) 578-2559

Mailing Address:

Caterpillar Inc.

Industrial Power Systems

P.O. Box 610

Mossville, IL 61552

www.cat-industrial.com

E-mail: cat_power@cat.com

Materials and specifications are subject to change without notice. Rating ranges listed include the lowest and highest available for a specific engine or family of engines. Load factor and time at rated load and speed will determine the best engine/rating match. CAT, CATERPILLAR, their respective logos, ACERT, "Caterpillar Yellow" and the POWER EDGE trade dress, as well as corporate and product identity used herein are trademarks of Caterpillar and may not be used without permission.