



# 150-Ton Air-Cooled Rental Chiller Module



## **MODULE COMPONENTS**

- One (1) 150-ton York air-cooled reciprocating chiller with a microcomputer control center for operating and safety controls
- Separate refrigeration circuits to provide redundancy up to two (2) 75-ton compressors
- One (1) 20 hp Bell and Gossett pump that delivers 250-700 gpm (360 gpm nominal) at 100 feet of head pressure (this provides flexibility for systems requiring different flows)
- Triple-duty valves to dial in the proper flow to evaporator
- Butterfly valves to dial in the evaporator bypass loop
- In-line water strainers to protect system from foreign objects
- Insulated water lines to prevent condensation
- Refrigeration lines fitted with vibration absorbers to prevent vibration damage
- Low flow bypass on the evaporator line to prevent chiller shutdown in low flow conditions

## **CAT® ISO CONTAINER AND TRAILER**

- One (1) 20-foot ISO container
- Two (2) 6-inch flanged, evaporator water connections with external access for ease of connections
- Storage box on chassis for storage of hose, cable, and fittings
- Lockable bus bar access door to keep unauthorized personnel from accessing high voltage cables

- Lockable doors to prevent unauthorized entry
- Air ride chassis to help prevent road vibration
- Removable air intake louvers to provide ease of serviceability

## **ELECTRICAL AND CONTROL PANELS**

- Total Full Load Amps = 329 amps @ 480 volt/ 3 phase/60 hertz
- Bus bar configuration with one (1) feed including three (3) phases and one (1) ground
- Caterpillar Motor Control Center provides protection from power surges and peaks, and provides disconnects for each compressor and pump
- Phase rotation light to ensure proper power installation
- “Control Power On” lamp to notify user that 480 volt is present
- Convenient 120 volt inlets allow user to supply power to warm up crankcase heaters prior to running, which allows 480 volt power to be disconnected
- 120 VAC lighting for lighting without 480 volt power supply
- Copper distribution buswork designed per UL specifications
- Two (2) 250 amp feeder circuit breakers, one per compressor
- NEMA rated motor starters for circulating pumps with HAND-OFF-AUTO controls for each pump
- One (1) 3 kV•A control transformer for module auxiliaries

### DIMENSIONS

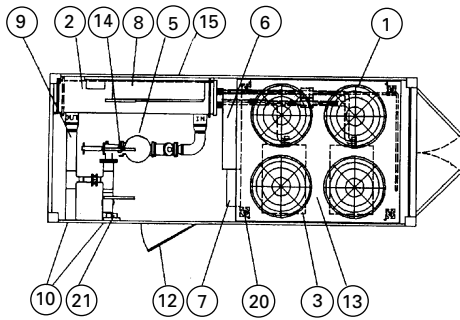

Floor Layout  
150-Ton Chiller Unit

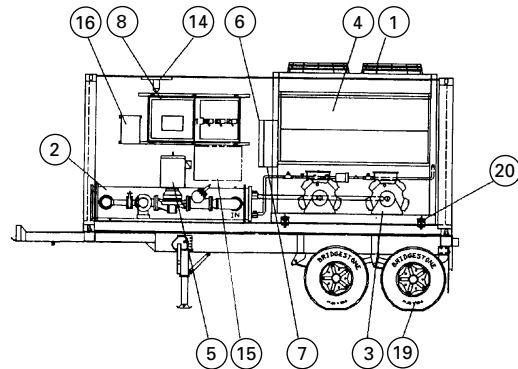

Interior Detail  
150-Ton Chiller Unit

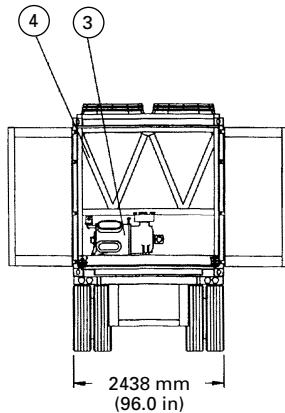

Rear View with Doors Open  
150-Ton Chiller Unit

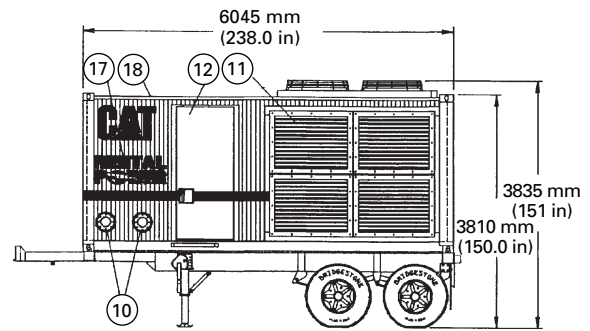

Side View  
150-Ton Chiller Unit

- |  |   |                                   |
|--|---|-----------------------------------|
| ① Reciprocating Liquid Chiller         | ⑧ Distribution/Motor Control Center     | ⑮ Exterior Electrical Connections |
| ② Dual-Circuit Cooler                  | ⑨ 6-inch System Piping                  | ⑯ Literature Box                  |
| ③ Semi-Hermetic Compressor Motor       | ⑩ Customer Connections – 6-inch flanges | ⑰ Caterpillar Rental Decals       |
| ④ Black Fins Condenser Coils           | ⑪ Exterior Ventilation Louver – Bolt-In | ⑱ Undercarriage Arrangement       |
| ⑤ In-Line Centrifugal Circulation Pump | ⑫ Entrance Door                         | ⑳ Vibration Isolators             |
| ⑥ Chiller Microcomputer Control Center | ⑬ Roof Exhaust Opening                  | ㉑ Light Switch and Receptacle     |
| ⑦ Power Panel for Compressors and Fans | ⑭ 120 VAC Light                         |                                   |

The container meets or exceeds the following standards and regulations.

- ISO/TC 104 requirements for cargo containers.
- ANSI/MH5.1 basic requirements for closed van containers.
- UIC code 592-1 International Union of Railway.

Maximum weight allowed on interstate highways is 34 000 lbs. on rear axles (40 000 lbs. with permit). This unit typically weighs 25 000 lbs. as shipped. The complete unit weighs 31 000 lbs. with chassis. Empty chassis weighs 6000 lbs. These weights do not include tractor.

Consult your Caterpillar representative for details.