

Model PB2-10
Nominal 150 GPM

STANDARD FEATURES

- Compact rugged steel or aluminum transport frame.
- Fork lift tubes
- Industrial grade pump suitable for commercial or industrial duty.
- Cam-lock water connections, 4".
- Suction line strainer.
- Triple duty valve.
- Totally enclosed fan cooled motor.
- Power cable with pin/sleeve connector.
- NEMA 4 control center.
- Main power breaker with external handle.
- Motor starter with thermal overloads.
- Control transformer with circuit breakers.
- Hand-Off-Auto switch.
- Plug receptacle for remote Stop-Start.

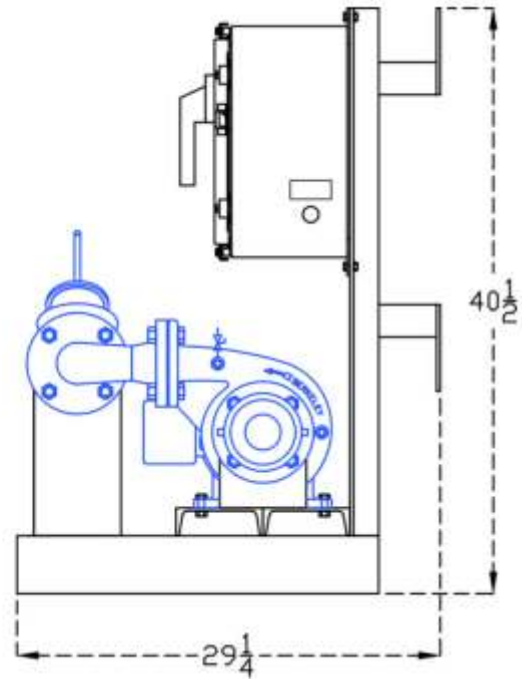
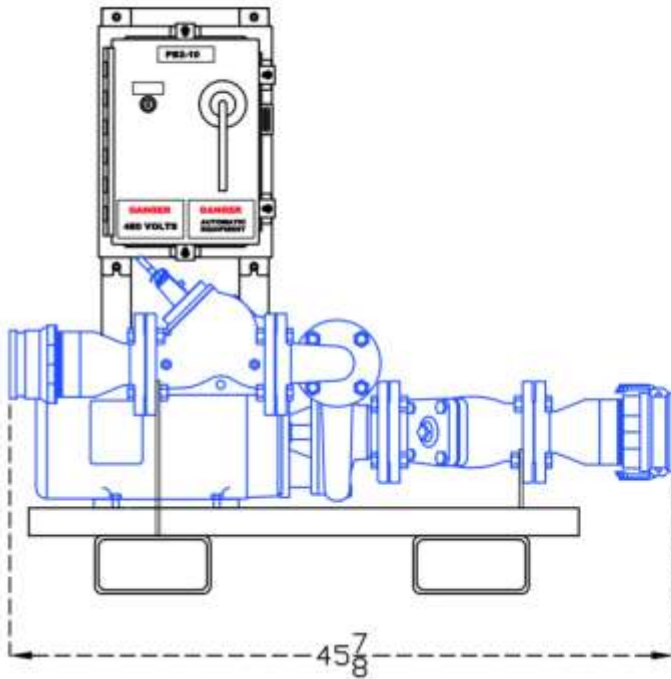

Approximate Shipping Weight (Steel Frame) - 565 LBS, (Aluminum Frame) - 440 LBS
Electrical Requirements - Full Load Amps 13.5, Service Factor Amps 15.4, 460/60/3



Model PB2-10 Nominal 150 GPM

PUMP CAPACITY

Nominal RPM 3600

Based on Fresh Water @ 68 deg. F

Impeller Diameter: 6-3/16"

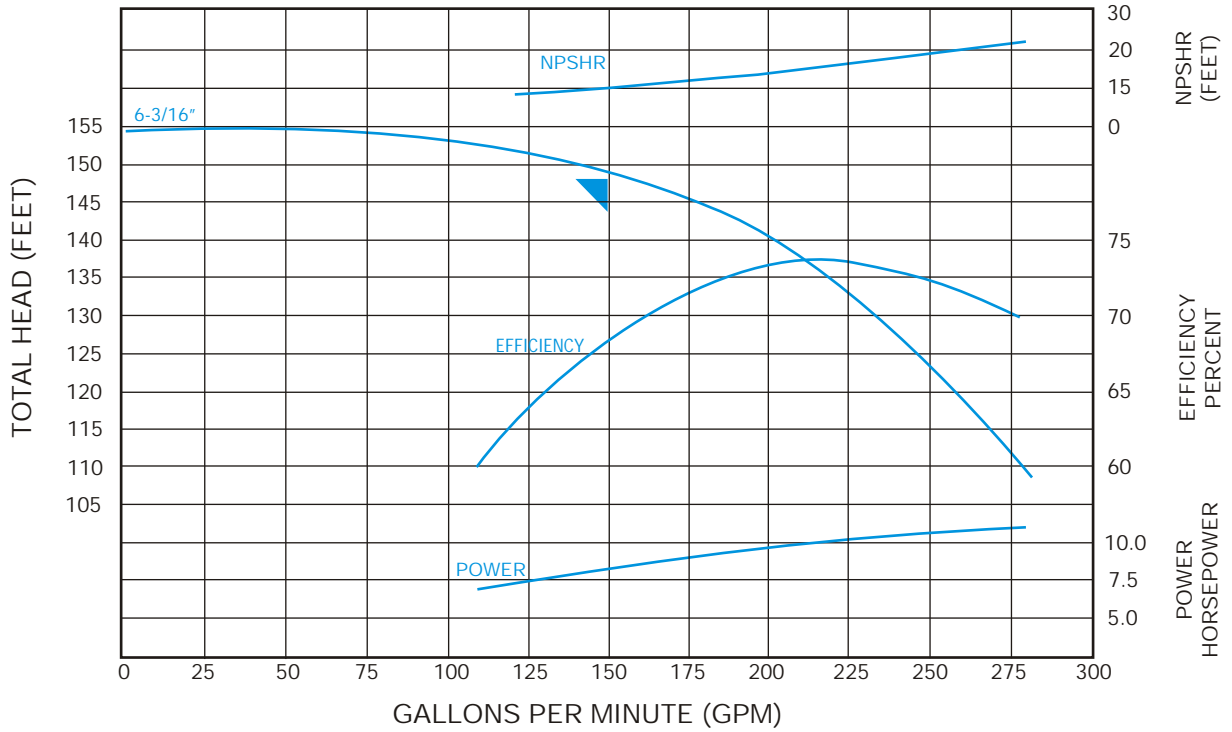

2-1/2" TRIPLE DUTY VALVE

