

Model PB2.5-15
Nominal 250 GPM

STANDARD FEATURES

- Compact rugged steel or aluminum transport frame.
- Fork lift tubes
- Industrial grade pump suitable for commercial or industrial duty.
- Victaulic water connections.
- Suction line strainer.
- Triple duty valve.
- Totally enclosed fan cooled motor.
- Power cable with pin/sleeve connector.
- NEMA 4 control center.
- Main power breaker with external handle.
- Motor starter with thermal overloads.
- Control transformer with circuit breakers.
- Hand-Off-Auto switch.
- Plug receptacle for remote Stop-Start.

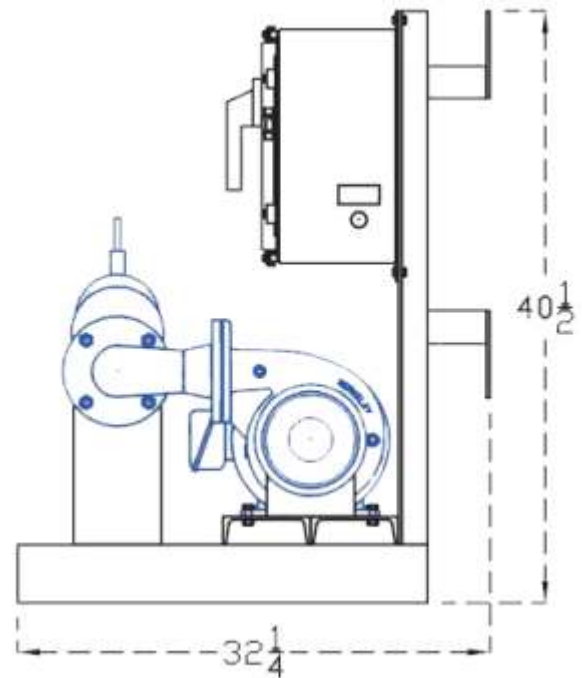
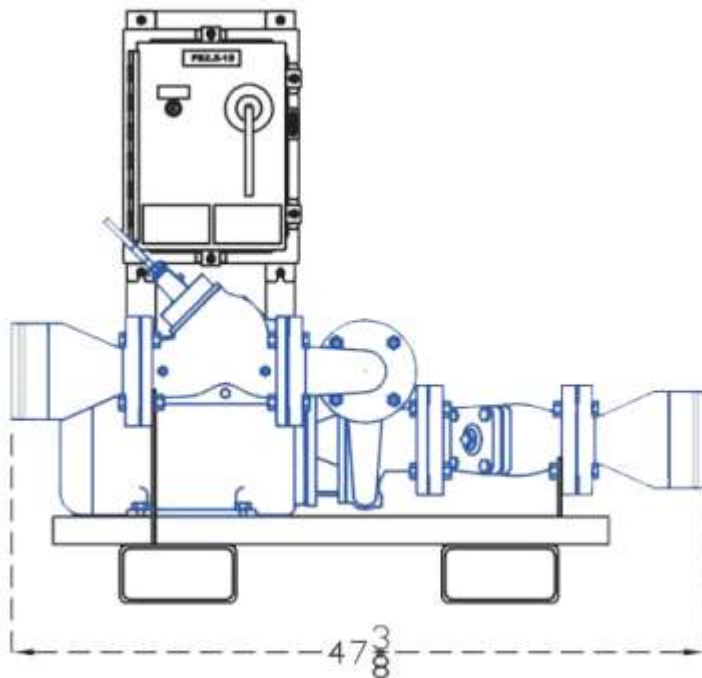

Approximate Shipping Weight (Steel Frame) - 675 LBS, (Aluminum Frame) - 550 LBS
Electrical Requirements - Full Load Amps 19.3, Service Factor Amps 24.5, 460/60/3

Model PB2.5-15 Nominal 250 GPM

PUMP CAPACITY

Nominal RPM 3600

Based on Fresh Water @ 68 deg. F

Impeller Diameter: 6-1/2"

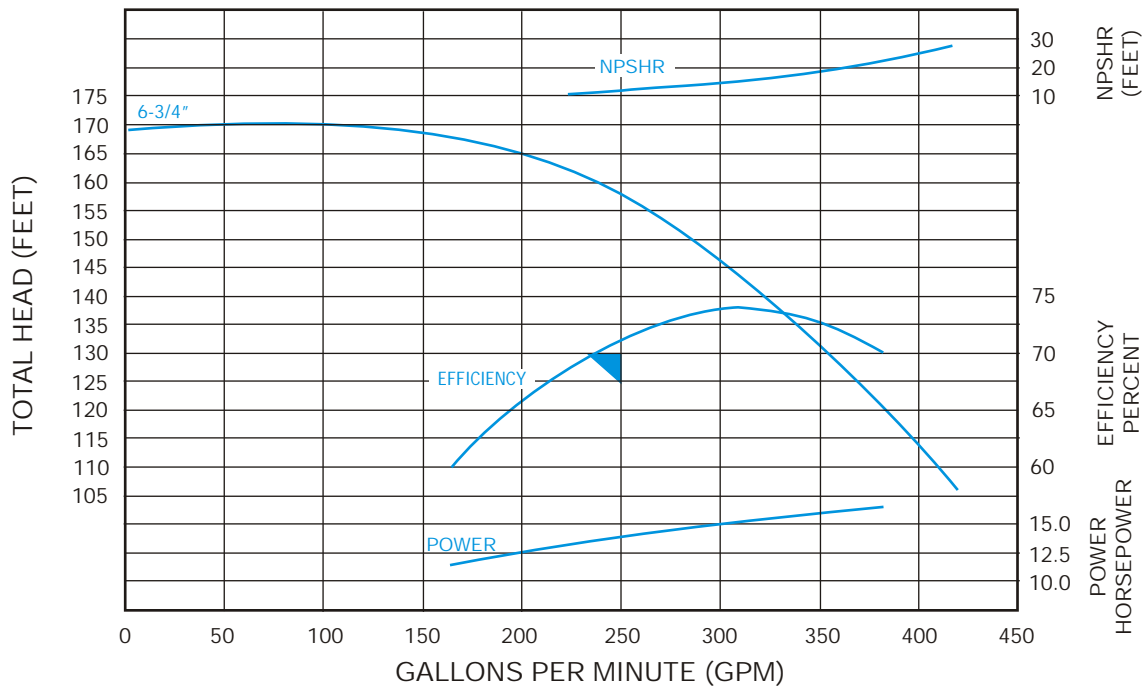

3" TRIPLE DUTY VALVE

