

Model PB4-40  
Nominal 900 GPM

## TEMPERATURE CONTROL EQUIPMENT

### HEAVY DUTY PORTABLE PUMPING PACKAGE MODEL PB4-40      NOMINAL 900 GPM

#### STANDARD FEATURES

- Compact rugged aluminum transport frame.
- Steel transport frame available as an option.
- Fork lift tubes.
- Industrial grade pump suitable for commercial or industrial duty.
- Victaulic water connections, 6".
- Triple duty valve, 6".
- High efficiency 40 HP, TEFC motor.
- NEMA 4 stainless steel control center.
- Power cable with pin/sleeve connector.
- Main power breaker with external handle.
- Motor starter with thermal overloads.
- Control transformer with circuit breakers.
- Hand-Off-Auto switch.
- Plug receptacle for remote Stop-Start.
- All electrical components are CSA approved.

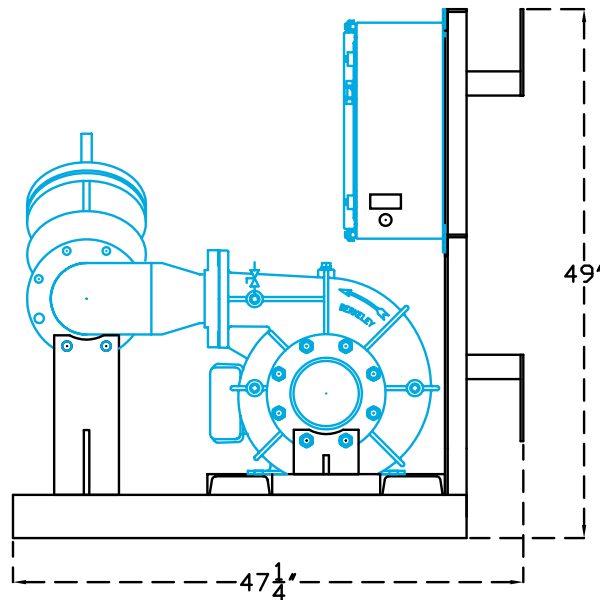
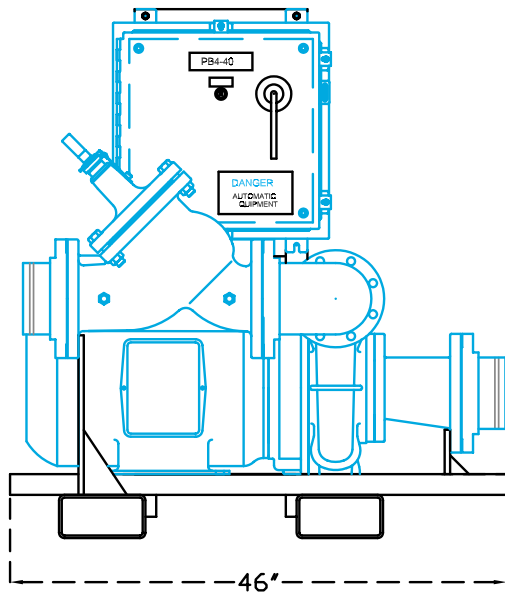

#### ELECTRICAL REQUIREMENTS

Full Load Amps 48.3 at 460/60/3, Service Factor Amps 55.5

Approximate Shipping Weight (Aluminum Frame) 1,224 lbs., (Steel Frame) 1,402 lbs.



## PUMP MODEL PB4-40

### PUMP CAPACITY

Nominal RPM 1750

Based on Fresh Water @ 68 deg. F

Impeller Diameter: 12-1/8"

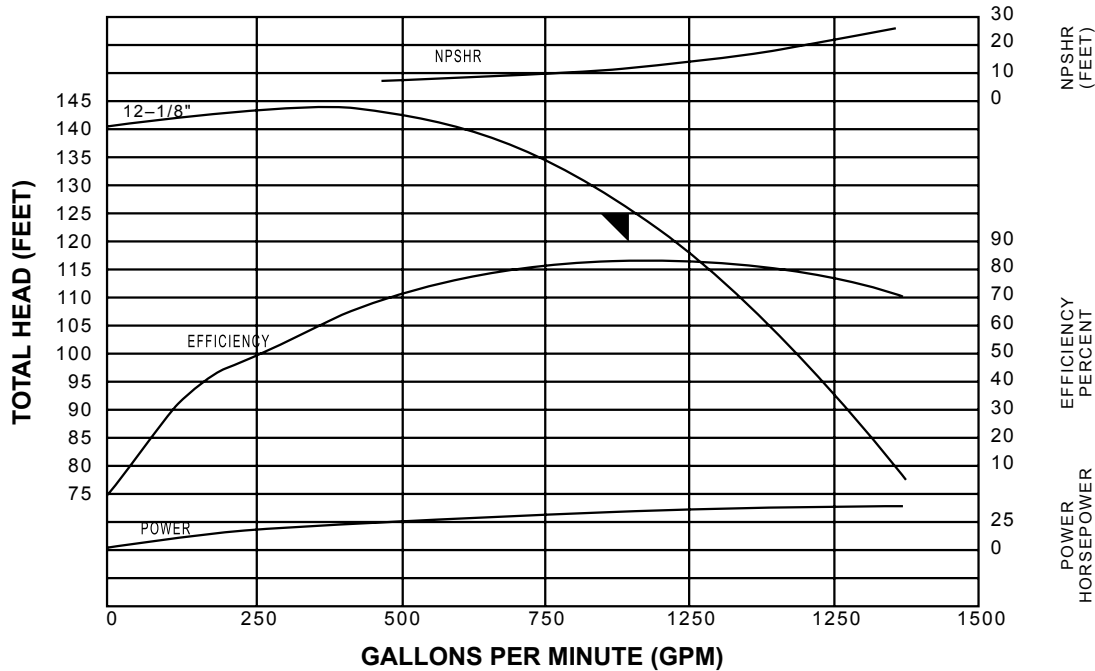

### 6" TRIPLE DUTY VALVE

