

TEMPERATURE CONTROL EQUIPMENT

HEAVY DUTY PORTABLE PUMPING PACKAGE MODEL PB6-50 NOMINAL 1000 GPM

STANDARD FEATURES

- Compact rugged steel transport frame
- Fork lift tubes
- Industrial grade pump suitable for commercial or industrial duty
- Victaulic water connections, 8"
- Triple duty valve
- High efficiency 50 HP, TEFC motor
- NEMA 4 stainless steel control center
- Power cable with pin/sleeve connector
- Main power breaker with external handle
- Motor starter with thermal overloads
- Control transformer with circuit breakers
- Hand-Off-Auto switch
- Plug receptacle for remote Stop-Start
- All electrical components are CSA approved

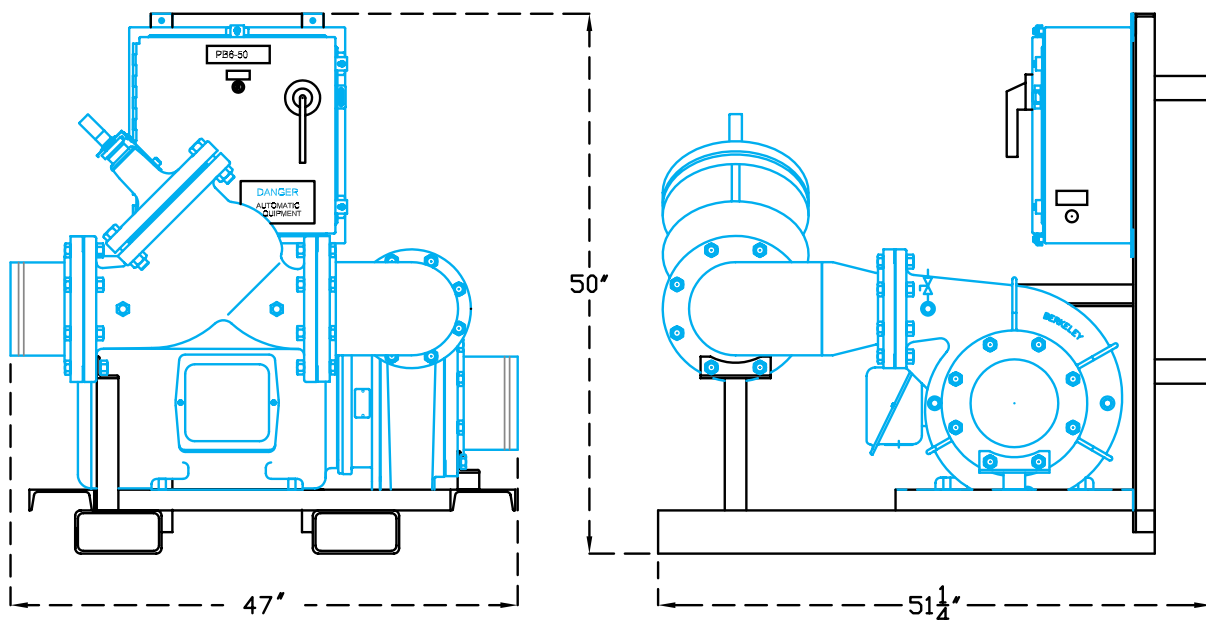

ELECTRICAL REQUIREMENTS

Full Load Amps 56.5 at 460/60/3

Approximate Shipping Weight 1,722 lbs.



PUMP MODEL PB6-50

PUMP CAPACITY

Nominal RPM 1800

Based on Fresh Water @ 68 deg. F

Impeller Diameter: 13-1/4"

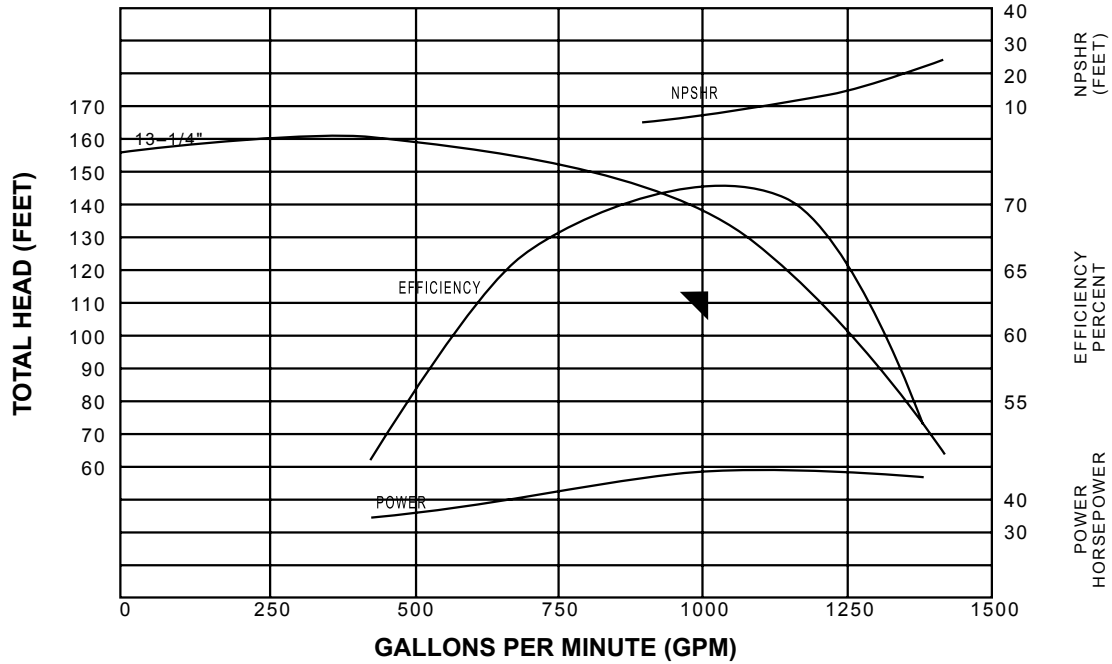

8" TRIPLE DUTY VALVE

