

# OIL-FREE ROTARY SCREW AIR COMPRESSORS

---

100 to 200 HP

Sullair DS Series Compressors.

When the only acceptable standard  
is 100% oil-free air.



# SULLAIR

## SULLAIR: A COMPANY WITH A FOCUS

*Sullair Asia's newly completed assembly facility in Chiwan, China provides a manufacturing base to serve customers in the growing Asian market*



### A focus on rotary screw technology

Sullair Corporation, a subsidiary of Sundstrand Corporation, is one of the world's leading authorities on rotary screw compression technology. Since it began manufacturing rotary screw compressors in 1965, Sullair has concentrated on this area of specialization. Maintaining a single-point focus, Sullair uses its extensive resources in Michigan City, Indiana to develop and advance rotary screw technology. As a result, the company continues to compile a body of research and expertise that is unparalleled in the field.

### Unchallenged leadership

Product specialization, combined with an ISO 9001 certified quality system, has enabled Sullair to become the only manufacturer to offer a three-year air end warranty as standard on its oil-free compressors. Resting on a solid base of experience and innovation, Sullair's leadership in rotary screw technology is unchallenged in the world today.

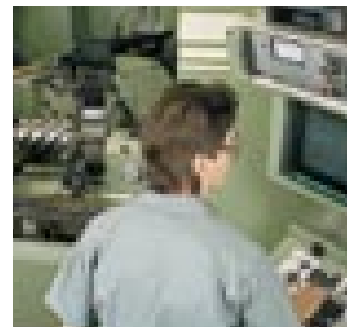

# RESSOR COMPANY USED VISION.

*Sullair Europe's manufacturing complex in Montbrison, France supports the full range of Sullair products and services to customers in Europe, Africa and the Middle East.*

*Sullair Corporation headquarters in Michigan City, Indiana includes an ISO 9001 certified manufacturing system that is among the most advanced in the world.*



## Global reach

Sullair has positioned itself to serve the world marketplace. In addition to its manufacturing complex in the U.S., Sullair has manufacturing facilities in China and France. From these centers, Sullair coordinates a sales and service network that provides comprehensive product support to customers around the world.



*Left—Sullair's Statistical Process Control (SPC) system monitors rotor quality standards to assure consistent compressor performance.*

# COMPRESSORS

## SULLAIR: OIL-FREE ROTARY SCREW

### A natural progression

For Sullair, widely known for its oil-flooded compressors, the development of an oil-free compressor was a natural progression. Using its expertise in fluid-injected screw technology, Sullair designed the DS Series to deliver the ultimate in compressed air quality: oil-free air.

### Oil-free compression

With non-contacting carbon ring seals that allow no lubricant to enter the compression

chamber, the Sullair oil-free compressor provides critical quality oil-free air for sensitive applications like food and beverage, pharmaceutical, chemical, textile and electronics production.

### No contaminating particles

The compressor's rotors and housing are cut, then coated with USFDA (U.S. Food and Drug Administration)-approved material to inhibit corrosion and minimize clearances. Because it operates without rotor-to-rotor



# COMPRESSION AND DEPENDABILITY.

contact, the DS compressor produces no wear particles to contaminate the airstream and create costly maintenance problems, as is the case with piston-type compressors.

## Flexible product range

The Sullair oil-free compressors comprise a range of flows and pressures from 100 to 200 hp (75 to 132 kW). This two-stage rotary screw design features intercooling between the stages for increased operating efficiency. Air- or water-cooled models are available.



## Sullair keeps it simple.

The rotary screw is the simplest method of compressing air. At Sullair, we know—because we've been doing it for more than 30 years.

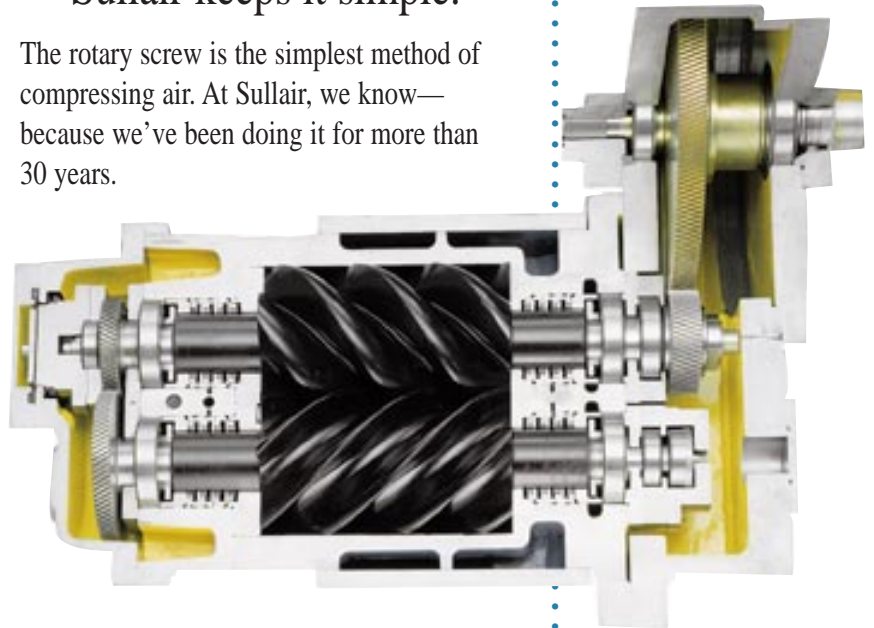

To develop the DS, we took our expertise in lubricated screws and applied it to oil-free compressors. The advantage to you: a compressor that's easy to operate and maintain, because Sullair rotary screw simplicity is built in.

*Fact: Sullair has been packaging oil-free compressors since 1981.*

# DESIGN

## SULLAIR: EXCEPTIONAL DESIGN EXPERTISE COME TOGETHER

### 1 *The air end*

AGMA 12 precision drive gears are designed to extend air end life.  
Gear-driven oil pump ensures lubrication at startup; no motor-driven oil pump required.  
Carbon ring seals ensure sealing without damage to the shaft.  
Sullair's exclusive three-year air end warranty.

### 2 *Premium efficiency motor*

Exceeds EPACT (Energy Policy Act) 1997 standard.  
Reduces electrical costs.

### 3 *NEMA 4 standard*

Watertight, corrosion resistant.  
Extends component life.

### 4 *Sullair Supervisor II microprocessor*

Built-in sequencing capabilities for automatic load sharing.  
Accurately monitors and controls the compressor.  
Constantly displays essential functions.

### 5 *Stainless steel control tubing*

Highly resistant to corrosion.  
Extends component life.

### 6 *First- and second-stage silencer/dampers*

Reduce noise and flow pulsations.  
Protect compressor and system.

### 7 *SAE O-ring fittings*

Assure a leak-free oil system.

### 8 *Enclosure with removable panels*

Quick-release panels for easy maintenance.  
Multi-layer foam insulation reduces noise levels to 78 dBA.  
Enhanced package appearance.

### 9 *Three stage intake filter*

Providing superior filtration.  
99.9% efficient per SAE J726 (Society of Automotive Engineers).

### 10 *Vibration isolation mounts under the motor and compressor*

Provides vibration-free operation.



# DESIGN AND ROTARY SCREW IN OIL-FREE COMPRESSORS.

## *Made in U.S.A.*

All major components manufactured, assembled and tested in one location. Components made of highest quality materials.

## *Minimal maintenance*

No interim intervention required. Annual maintenance only.

*Fact: Sullair has more than 30-years of experience with rotary screw air ends. Sullair offers a three-year warranty on the oil-free compressor air end.*



# BENEFITS

# SULLAIR: BUILT PROVIDE IMPORT

## Separate, easy-to-adjust valves



The Sullair oil-free compressor has separate inlet and blow down valves of simple, rugged design for easy adjustment and maintenance. These individual valves, unlike some integral designs, do not use critical pressure balancing holes that could clog and malfunction. In the unlikely event of valve damage, replacement is easy and inexpensive, since these valves are separate assemblies. No expensive repair kits are required.

## Reliable rotary screw air end

The compressor unit is designed and built by Sullair, a manufacturer that has specialized in rotary screw technology since 1965. Sullair has the widest range of screw compressors in the market and has been delivering oil-free machines since 1981.

**The rotor assembly** is the heart of any screw compressor. For its screw compressors, Sullair has designed extremely heavy-duty rotors. Using bearings with an L10 life of over 100,000 hours, the Sullair DS compressor is one of the few oil-free designs rugged enough for a full voltage motor start.



**Rotors and rotor housings** are precision coated to inhibit corrosion and prohibit contamination. The coating is approved by the U.S. Food and Drug Administration as a food-grade PTFE, to ensure contaminant-free conditions.

**Vibration monitoring for predictive maintenance.** Precision ground accelerometer connections allow customers to monitor air end bearing condition and predict compressor maintenance needs.

**Proven reliability.** The fact that more than 150,000 Sullair compressors are at work in the world today is solid proof of their dependability.

# T-IN FEATURES TANT BENEFITS.

## Choice of air-cooled or water-cooled models

The Sullair oil-free compressor is available with either air-cooling or water-cooling. The air-cooled model uses high efficiency modular fin and tube aluminum heat exchangers. If damaged, each section can be



replaced individually to reduce maintenance costs. The water-cooled model uses non-proprietary, readily available shell and tube heat exchangers, which are interchangeable



on the first and second stage for reduced parts requirements. These coolers may be replaced at a fraction of the cost of competitor's coolers. Stainless steel cooler tubes are standard for greater life.

## Extremely “user-friendly” Supervisor II

This state-of-the-art microprocessor has a simple graphical illustration of the monitored functions and an easy-to-use keypad. Automatic stop/start, as well as sequencing, is standard.

**Phase monitor relay** protects the unit from poor quality electricity.

**Power failure restart** mechanism will restart the machine in the event of a power failure.

**Choice of languages and numerical units.** Select English, Spanish, German, French or Italian languages and metric or English units.

**Malfunction alert.** Operator is alerted to malfunction by an alarm and flashing indicators, showing first out indication of the initial problem.

**Stop/Reset key.** This built-in safeguard prevents accidental starting

**Two-way communications.** RS 485 communications port allows for remote input of desired operating parameters and output of actual readings.

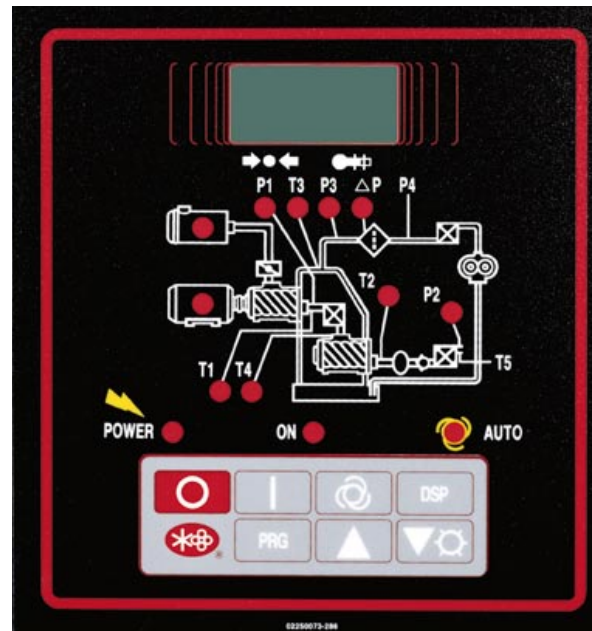

# SUPPORT



## Worldwide parts and training availability

## Global service support



Because Sullair believes that using genuine Sullair replacement parts is essential to premium compressor performance, we assure that these are readily available on a global basis. Through our computer-based system, our distributors can procure Sullair replacement parts for any piece of Sullair equipment in any part of the world, quickly and efficiently.

Sullair offers hands-on training programs in the proper operation and maintenance of Sullair equipment at dedicated training centers in the U.S., Europe and China, as well as on-site training in every area of the world.



Your investment is supported by an experienced team of compressed air experts. Our global network of authorized Sullair distributors and field service representatives provides responsive, knowledgeable service, including on-site and factory-based technical assistance, to Sullair customers around the world.







[www.sullair.com](http://www.sullair.com)

SULLAIR CORPORATION, Subsidiary of Sundstrand Corporation, 3700 E. Michigan Blvd., Michigan City, IN 46360 Telephone: 1-219-879-5451 Fax: 1-219-874-1252  
SULLAIR ASIA, 1 Sullair Road, Chiwan, Shenzhen, China 518068 Telephone: (86) 755-6853477 or (86) 755-6851686 Fax: (86) 755-6853473  
SULLAIR TAIWAN LTD., 3F-1, No. 248 Chung Shan Road, Lin-Kou Hsiang, Taipei Hsien Telephone: (02) 2601-3500 Fax: (02) 2601-3032  
SULLAIR EUROPE, Zone des Grange, B.P. 82, 42602 Montbrison, Cedex, France Telephone: (33) 4.77.96.84.70 Fax: (33) 4.77.96.84.99  
SULLAIR ARGENTINA, Gonclaves Dias 1145, 1276 Buenos Aires, Argentina Telephone: 541-303-0621 Fax: 541-303-0626  
SULLAIR ASIA LTD., 74 Joo Koon Circle, Jurong, Singapore 629093 Telephone: (65) 861-1211 Fax: (65) 861-2967

SSL-15000 Specifications subject to change without notice. © Copyright 1998 Sullair Corporation. All rights reserved. EA/10/98/10

