

Heavy Duty Portable Air Cooled Chiller

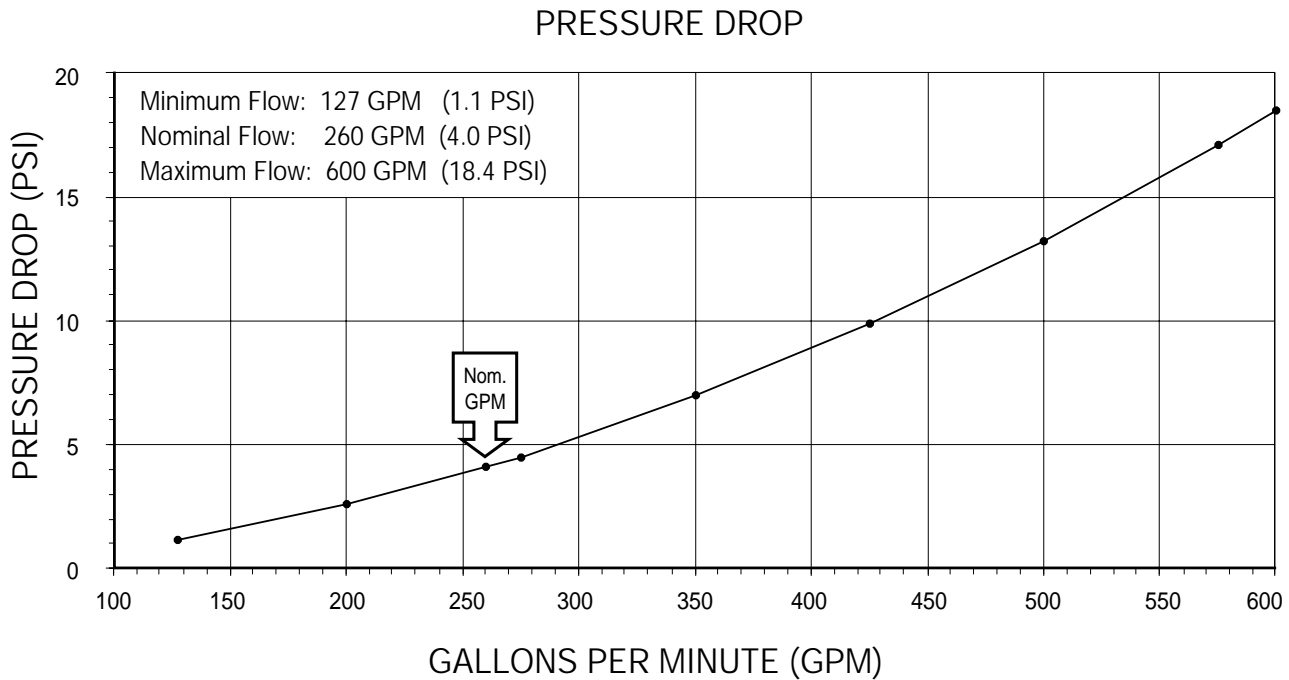

Model PY -100
Nominal 102.9 Tons

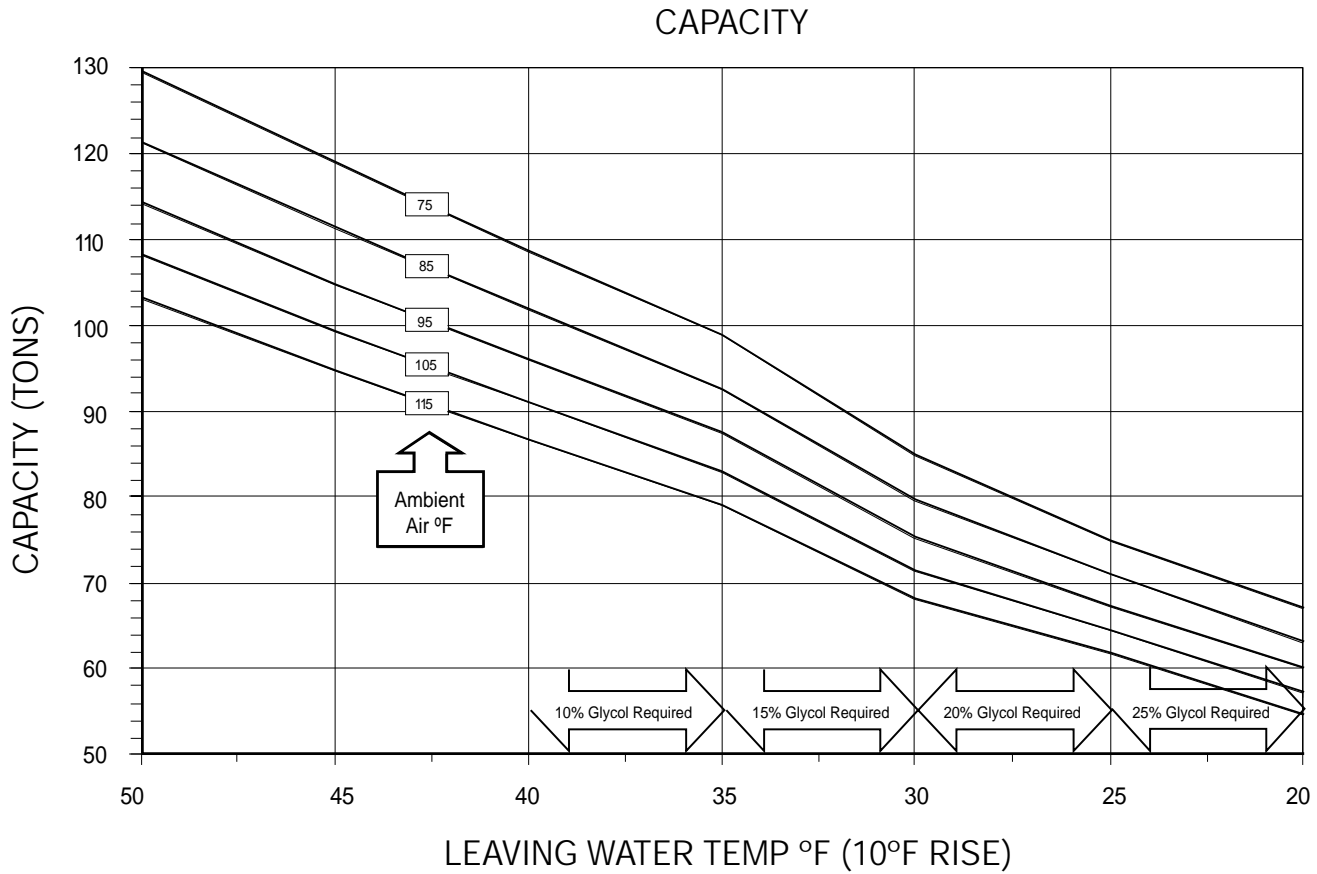

Model PY -100
Nominal 102.9 Tons

STANDARD FEATURES

- Compact rugged steel transport frame
- Fork lift pockets and tie down eyes
- Top mounted 4 point lifting lugs
- Industrial grade chiller suitable for commercial or process cooling duty
- Dual compressors with independent refrigerant circuits
- Chilled liquid settings from 20-55° F
- Victaulic water connections, 6 "
- Automatic air vents
- Single point fill and drain connections
- Differential pressure gauge with flow safety interlock
- Unit mounted flow comparison chart
- Chilled water pump interface for automatic operation
- Twist-lock connection for main power
- Push-to-test phase rotation indicator
- Enclosed main power breaker with lockable external handle
- Complete DDC control center
- 40 Character Alpha-Numeric display
- Network compatible controls interface
- Pump power connection with pre-phased lockable breaker

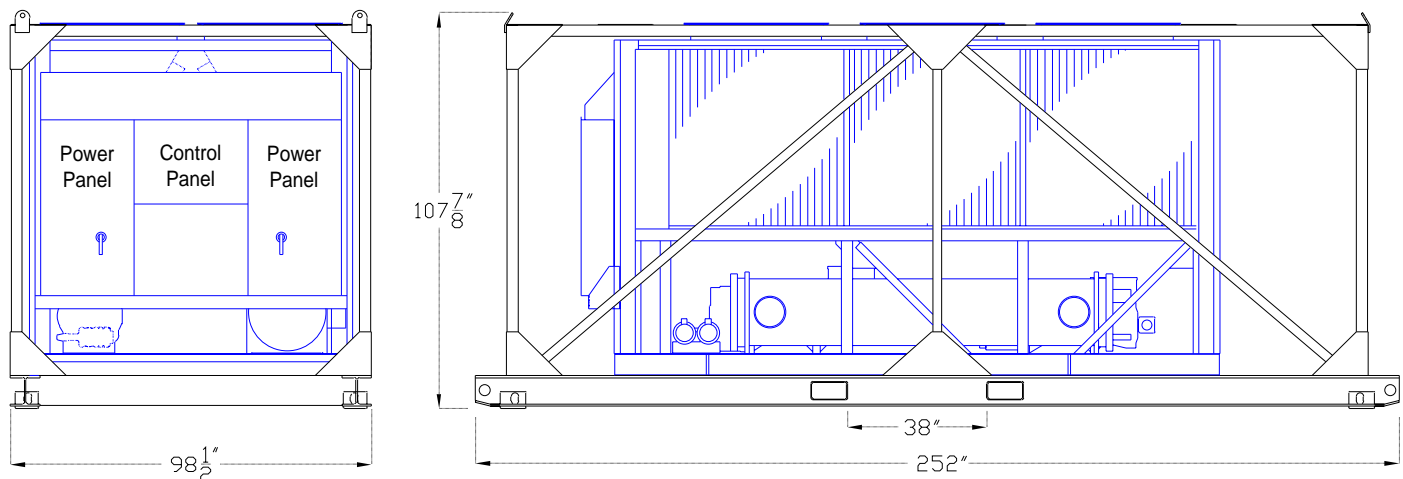

Approximate Shipping Weight - 13,820 lbs., Operating Weight - 14,290 lbs.

Main Power Breaker Range (Chiller Only): 225 Amps Min. - 400 Amps Max.

(With 15 HP Pump: 245 Amps Min. - 400 Amps Max.) (With 25 HP Pump: 265 Amps Min. - 400 Amps Max.)

