

Heavy Duty Portable Pumping Package

CATERPILLAR®

Model PB6-60 Nominal 1200 GPM

STANDARD FEATURES

- Compact rugged steel transport frame
- Full fork lift tubes.
- Industrial grade pump suitable for commercial or industrial duty.
- Victaulic water connections, 8".
- Triple duty valve.
- Totally enclosed fan cooled motor
- Power cable with pin/sleeve connector
- NEMA 4 control center
- Main power breaker with external handle.
- Motor starter with thermal overloads.
- Control transformer with circuit breakers.
- Hand-Off-Auto switch.
- Plug receptacle for remote Stop-Start.

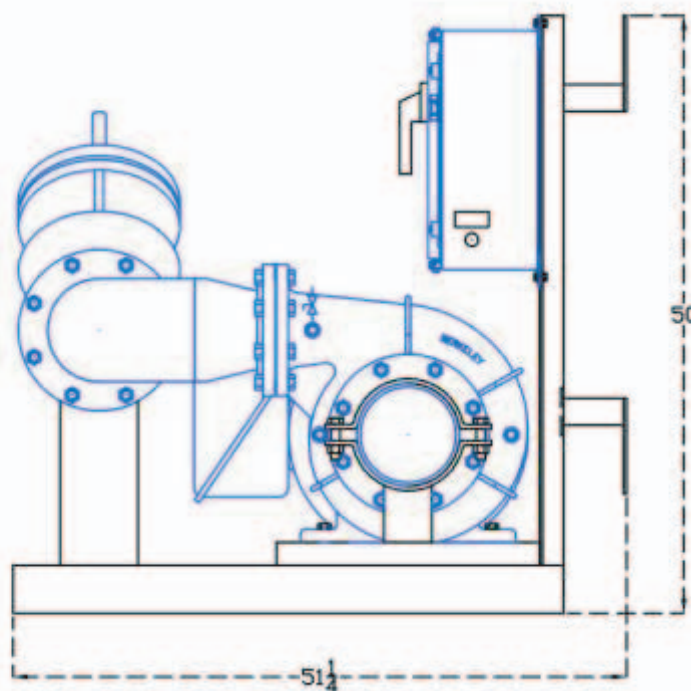
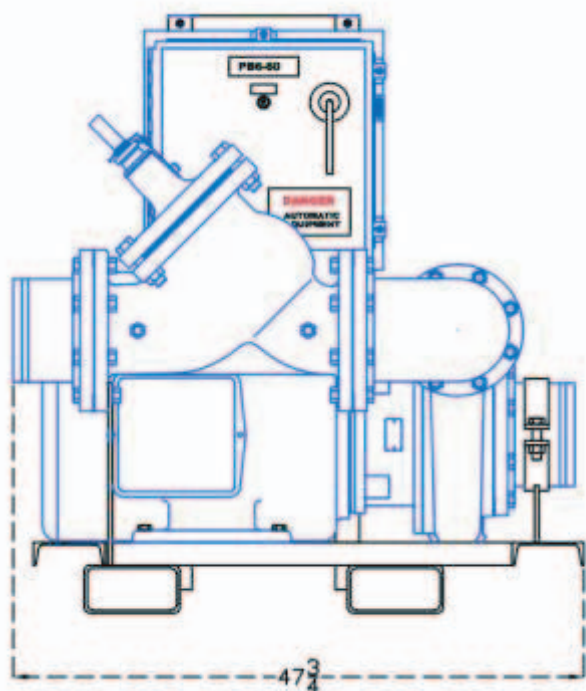

Approximate shipping weight - 1,975 LBS

Electrical requirements - Full Load Amps 91.0, Service Factor Amps 104.5, 460/60/3

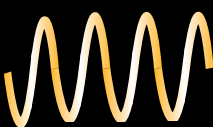

WHERE THE WORLD TURNS FOR POWER

Heavy Duty Portable Pumping Package



Model PB6-60 Nominal 1200 GPM

PUMP CAPACITY

Nominal RPM 1800

Based on Fresh Water @ 68 deg. F

Impeller Diameter: 12-3/16"

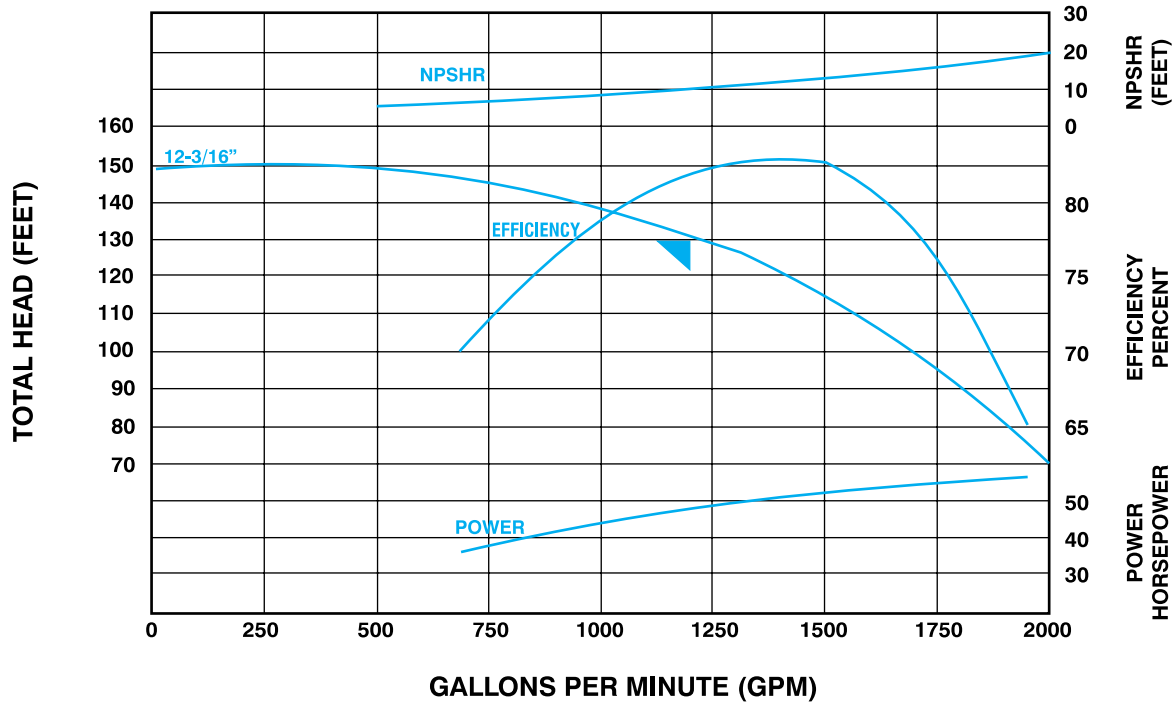

8" TRIPLE DUTY VALVE

