



UPS 1200 SERIES, SINGLE MODULE SYSTEM

1200 kVA/960 kW, 60 Hz

3 wire

Caterpillar is leading the power generation marketplace with Power Quality Solutions engineered to deliver unmatched flexibility, expandability, reliability and cost-effectiveness.

FEATURES

- Smallest available footprint
- 97% total system efficiency
- Harmonic cancellation
- Transient protection
- High-speed voltage regulation
- Power factor correction
- Top and bottom cable entry
- 40° C rating on entire system
- Low input current distortion
- Utilize kinetic power cell technology
- Remote monitoring
- Simple installation
- Low maintenance
- Field expandable ride-through
- Color user interface display
- Optional generator set start module

RELIABLE POWER PROTECTION FOR CRITICAL APPLICATIONS

Cat® UPS systems provide constant power protection against surges, sags and power interruptions that can disrupt operations or cause loss of valuable data or system capacity. Additionally, the use of the optional generator set start module can dramatically increase generator set starting reliability in a continuous power configuration.

SUPERIOR DESIGN

Superior system design and the use of robust digital components throughout the system yield the most reliable and trouble-free UPS system on the market. Protection is delivered in the industry's smallest package with the highest efficiency and superior performance.

GENERATOR SET INTEGRATION

By cancelling harmonic distortion, the 1200 Series operates seamlessly with generator sets to provide a higher total electrical load capacity without over-sizing the generator set. The 1200 Series effectively insulates the generator set from block loads and transients, and can improve its fault clearing capabilities. Programmable integration with standby generator sets assures greater system reliability and improves the total system operation.

WORLDWIDE PRODUCT SUPPORT

- Parts Distribution Centers are located worldwide with available service support through Caterpillar and the Cat Dealer Network.
- Factory certified service technicians are trained to support every aspect of your Cat UPS system.

FACTORY INSTALLED STANDARD & OPTIONAL EQUIPMENT

STANDARD FEATURES	OPTIONAL FEATURES
Full rated continuous duty static bypass switch	24 volt DC, generator set starting power
Redundant control power supplies	Additional flywheel available for increased ride through
Local Emergency Power Off (EPO)	Remote EPO
UPS View — monitoring/communication software	Remote status panel
RS232 and RS485 serial connection	SNMP Communication
Feature rich 10.4" color touch screen, graphical user interface	Maintenance bypass
Internal modem	Output Isolation Breaker
Programmable monitoring and alarm input and output contacts	
MODBUS Communication	
Redundant cooling fans	
Auto restart (programmable)	
Back feed protection	
Ethernet communication port	
Dual-flywheel energy storage cabinets	
Mounting hardware – seismic rated	
Voltage regulation and power factor correction	
Harmonic cancellation	

SPECIFICATIONS

INPUT	
Voltage	480 VAC 3 phase, 3-wire plus ground (from grounded wye source)
Voltage Range	+10%/-15% (programmable)
Frequency	60 Hz
Power Factor	0.99 at rated load and nominal voltage
<i>Harmonic Current Distortion</i>	
Linear load	<3% at 100% resistive load
Non-linear load	<8% with 100% non-linear load
Input frequency	60 Hz
Surge Withstand	Meets IEEE 587/ANSI C62.41
Walk-in	1 to 15 seconds (programmable)
Bypass Source	Same as input source — Synchronized frequency, phase and voltage
Bypass Voltage Window	+10/-15% (programmable within range)
OUTPUT	
Voltage	480 VAC 3 phase, 3-wire plus ground
<i>Voltage regulation</i>	
Steady-state	±1% of nominal for ±10% input balanced or unbalanced load 0.8 lag to 0.9 lead pf; 7% at -15% input voltage
Transient	±5% of nominal for 100% load step
Recovery Time	50 millisecond maximum
Bypass Trigger	Programmable up to ±10%

<i>Frequency Regulation</i>	
Normal Operation	Synchronized to input
Free Running	0.1% of nominal
Synch Window	Adjustable over a range of at least 0.3 Hz to 3 Hz
Frequency Slew Rate	Adjustable over a range of at least 0.2 Hz/second to 3 Hz/second
Load Power Factor	0.8 lag to 0.9 lead for specified regulation and rating. 0.4 lag to 0.7 lead with reduced regulation or load
<i>Voltage Unbalance & Distortion</i>	
Balanced Load	<1% voltage unbalance and <1° phase displacement
50% Unbalanced Load	<3% voltage unbalance and <3° phase displacement
Linear Load	<3% THD <2% SHD
100% Non Linear Voltage Distortion ¹	<5% THD
Voltage Imbalance	The UPS is capable of supporting any combination of unbalanced load that does not exceed the maximum phase currents and the total output limitations of the UPS
<i>Overload Capability (nominal line without bypass)</i>	
Continuous	105%
1 Minute	125%
5 Seconds	Up to 150%

¹ In accordance with EN50091-3

DIMENSIONS & WEIGHTS

<i>All Cabinets</i>		
Depth	1016 mm	40.0 in
Cabinet height (w/out DC bus)	1981 mm	78.0 in
System height (w/DC bus)	2319 mm	91.3 in
<i>Maintenance By-pass (option)</i>		
Width	533 mm	21.0 in
Weight	907 kg	2000 lb
<i>Bottom Entry (option)</i>		
Width	1067 mm	42.0 in
Weight	817 kg	1800 lb
<i>Input/Output</i>		
Width	1067 mm	42.0 in
Weight	1134 kg	2500 lb
<i>Static Switch</i>		
Width	1067 mm	42.0 in
Weight	923 kg	2035 lb
<i>Control (Note: ships attached to Inverter Cabinet)</i>		
Width	914 mm	36.0 in
Weight	907 kg	2000 lb
<i>Inverter (Note: ships attached to Control Cabinet)</i>		
Width	1067 mm	42.0 in
Weight	771 kg	1700 lb
<i>Energy Storage/each — 2 per standard system</i>		
Width	1067 mm	42.0 in
Weight	3040 kg	6700 lb

TECHNICAL DATA

Maximum kVA	1200
Maximum kW	960
Input voltage	480
Output voltage	480
AC input current Nominal amps	1205
Maximum amps incl. recharge	1600
AC output current nominal amps	1445
System efficiency (3-wire)	97%
Heat rejection	
*UPS 1200 Series 3W Nominal BTU/hr (kW) Worst Case BTU/hr (kW)	92,150 (27) 109,898 (32.2)

ENVIRONMENTAL

Acoustical noise	<77 dBA at 1.524 m (5 ft)
<i>Temperature</i>	
Operating	0° C to 40° C (32° F to 104° F)
Storage	-25° C to 70° C (-13° F to 158° F)
Humidity	5% to 95% (non-condensing)
Altitude	Up to 914.4 m (3000 ft); (derate operating temperature range for higher elevation)
Emissions and Immunity	FCC Class A, Subpart J of Part 15/EN 50091-2

CERTIFICATIONS

UL 1778 Listed
CUL CAN/CSA 22.2 No. 107.1 Listed

RIDE THROUGH TIMES (SEC)

Number of Flywheel Cabinets	100% load	75% load	50% load	25% load
2	13.5	17	26	50
3	20	25	39	75
4	27	34	52	100

UPS1200S SYSTEM FRONT ELEVATION (3 WIRE)

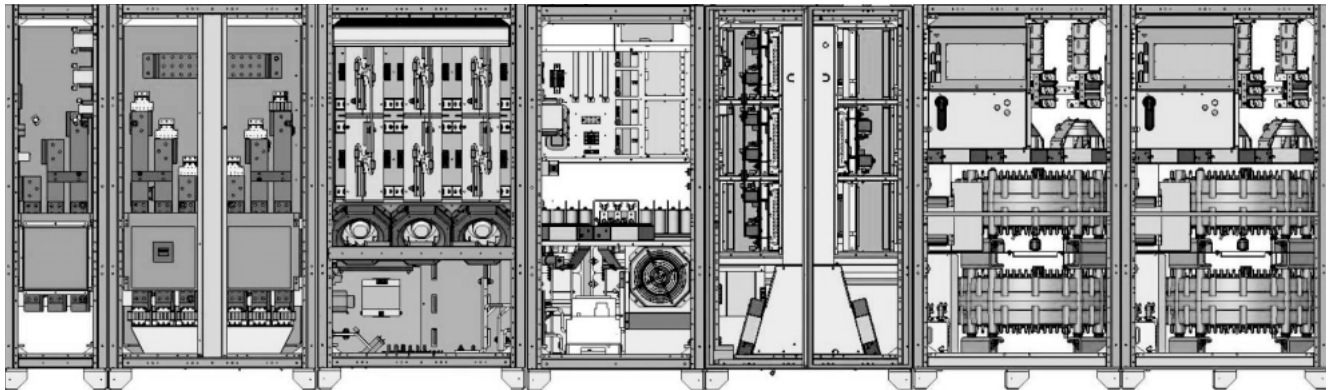

Bypass Input / Output Static Switches Controls Inverter Energy Storage

UPS1200S SYSTEM ONE LINE DIAGRAM (3 WIRE)

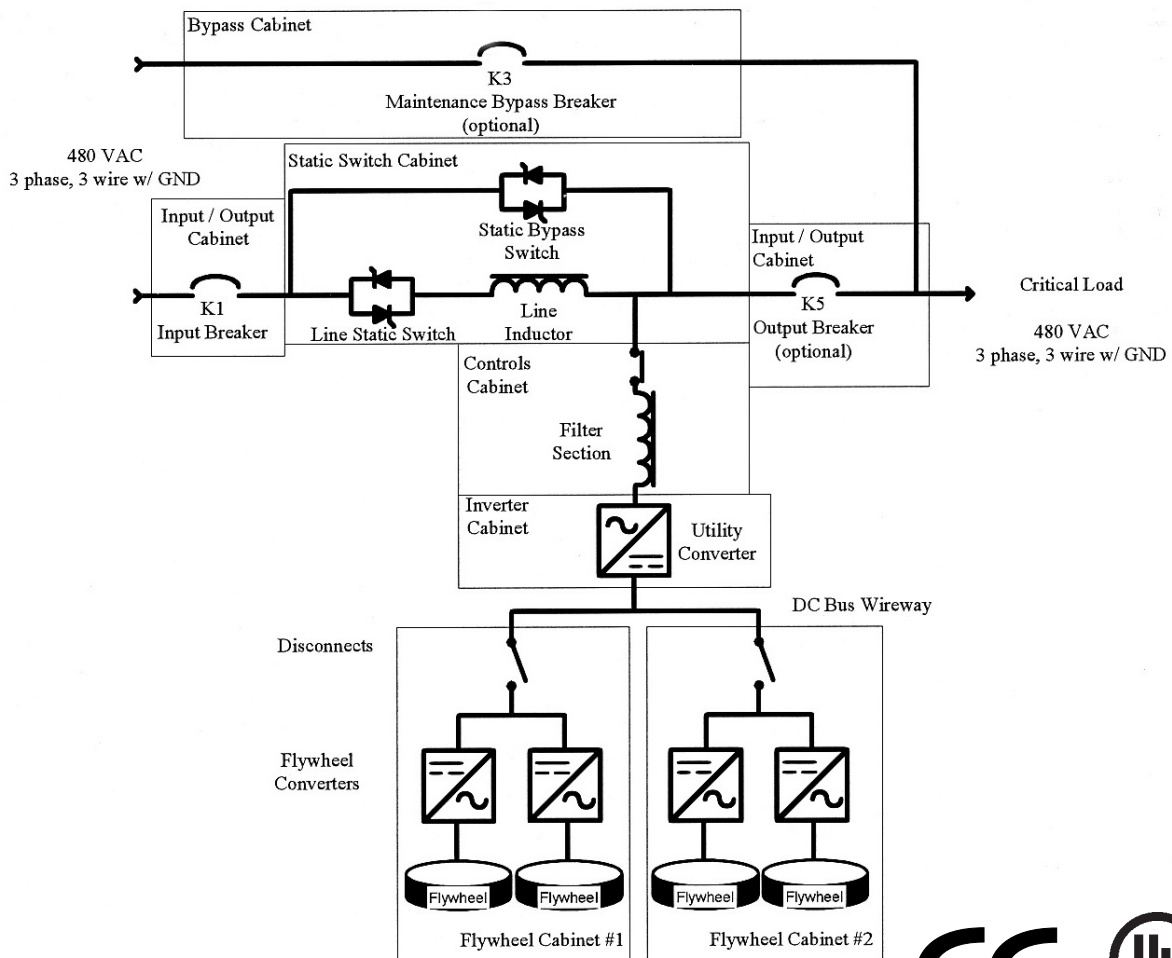

Information contained in this publication may be considered confidential.

Discretion is recommended when distributing.

Materials and specifications are subject to change without notice.

CAT, CATERPILLAR, their respective logos, "Caterpillar Yellow" and the POWER EDGE trade dress, as well as corporate and product identity used herein, are trademarks of Caterpillar and may not be used without permission.

www.cat-electricpower.com

© 2008 Caterpillar
All Rights Reserved.
Printed in U.S.A.