

# Cat® DG100 GAS GENERATOR SETS



Image shown may not reflect actual configuration.

Engine Model	6.2L V8 TCAC
No. of Cylinders	8
Bore x Stroke	101.6 mm x 95.3 mm
Displacement	6.2 Litre
Compression Ratio	9.8:1
Aspiration	Turbocharged & Aftercooled
Fuel System	Spark Ignition
Governor	Electronic

Model	Standby		Emissions Strategy
	Natural Gas ekW	Propane ekW	
DG100	100	89*	U.S. EPA Certified for Stationary Emergency

## PACKAGE PERFORMANCE

Performance	Standby	
	Natural Gas	Propane
Frequency	60 Hz	
Genset power rating, ekW	125	111
Genset power rating with fan @ 0.8 power factor	100	89
Performance number	EM6752	EM6753
<b>Fuel Consumption (% mech efficiency)</b>		
Minimum Running pressure to Electronic Pressure Regulator (EPR), psi (in. water)	0.25 (7)	0.25 (7)
Maximum Running pressure to Electronic Pressure Regulator (EPR), psi (in. water)	0.40 (11)	0.40 (11)
100% load with fan, kg/hr (ft³/hr)	27.7 (1255)	25.8 (482)
75% load with fan, kg/hr (ft³/hr)	21.9 (989)	20.2 (378)
50% load with fan, kg/hr (ft³/hr)	15.5 (701)	14.3 (268)
<b>Cooling System<sup>1</sup></b>		
Radiator air flow, m³/min (cfm)	-	
Radiator air flow restriction (system), kPa (in. water)	-	
Engine coolant capacity, L (gal)	7.60 (2.0)	
Radiator coolant capacity, L (gal)	19.0 (5.0)	
Total coolant capacity, L (gal)	26.6 (7.0)	
<b>Inlet Air</b>		
Combustion air inlet flow rate, m³/min (cfm) (kg/hr)	6.2 (219) (457.7)	5.1 (178.7) (372)
Maximum allowable intake air restriction, kPa (in. water)	3.48 (13.98)	
<b>Exhaust System</b>		
Exhaust stack gas temperature, °C (°F)	-	
Exhaust gas flow rate, m³/min (cfm) (kg/hr)	24.5 (846.1) (486)	19.5 (688.6) (396)
Exhaust system back pressure kPa (in. water)	15 (60.28)	
<b>Heat Rejection</b>		
Heat rejection to jacket water, ekW (Btu/min)	-	
Heat rejection to after cooler, ekW (Btu/min)	-	
Heat rejection to oil cooler, ekW (Btu/min)	-	
Heat rejection to atmosphere from engine, ekW (Btu/min)	-	
Heat rejection to exhaust (Total), ekW (Btu/min)	-	

# DG100 GAS GENERATOR SETS

## Electric Power



Performance	Standby	
	Natural Gas	Propane
<b>Lube System</b>		
Sump refill with filter, L (gal)	5.4 (1.43)	
Maximum oil temperature, °C (°F)	121 (250)	
Maximum oil capacity, L (gal)	4.7 (1.24)	
Minimum oil capacity, L (gal)	-	
<b>Emissions (Nominal)</b>		
NOx, mg/Nm <sup>3</sup> (g/hp-hr)	-	-
CO, mg/Nm <sup>3</sup> (g/hp-hr)	-	-

### ALTERNATOR DATA

DG100 – Natural Gas						
Alternator	60 Hz 3P					60 Hz 1P
	Voltages	480/277	240/120	240/139	208/120	600/346
Motor starting capability @ 30% Voltage Dip, skVA	336	263	336	264	349	229
Current, amps	150	301	301	347	120	417
Temperature rise, °C	105/40	105/40	105/40	105/40	105/40	105/40
Frame size	M2254L4	M2254L4	M2254L4	M2254L4	M2254L4	M2238L4
Excitation	PMG	PMG	PMG	PMG	PMG	PMG

DG100 – Propane						
Alternator	60 Hz 3P					60 Hz 1P
	Voltages	480/277	240/120	240/139	208/120	600/346
Motor starting capability @ 30% Voltage Dip, skVA	336	263	336	264	349	229
Current, amps	134	268	267	309	107	358
Temperature rise, °C	105/40	105/40	105/40	105/40	105/40	105/40
Frame size	M2254L4	M2254L4	M2254L4	M2254L4	M2254L4	M2238L4
Excitation	PMG	PMG	PMG	PMG	PMG	PMG

\*Preliminary Data – Subject to change without notice.

Motor starting capability is based on the assumption of 0.6 pf.

Temperature rise and Current in amps are based on the Standby rating at the respective voltages

# DG100 GAS GENERATOR SETS

## Electric Power



### WEIGHTS & DIMENSIONS

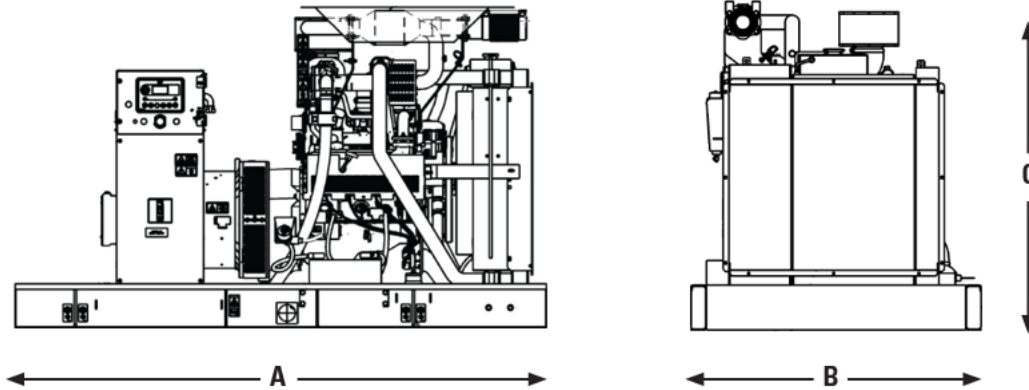

Length "A" mm (in)	Width "B" mm (in)	Height "C" mm (in)	Dry Weight Kg (lb)
2442 (96)*	1297 (51)*	1449 (57)*	1364 (3007)*

**Note:** General configuration not to be used for installation. See general dimension drawings for detail.  
\*Preliminary Data – Subject to change without notice.

### APPLICABLE CODES AND STANDARDS:

CSA C22.2 No 100-04, UL 489, UL 869, UL 2200, NFPA 37, NFPA 70, NFPA 99, NFPA 110, IBC, IEC60034-1, ISO 3046, ISO 8528, NEMA MG 1-22, NEMA MG 1-33.

#### DEFINITIONS AND CONDITIONS

- <sup>1</sup> For ambient and altitude capabilities consult your Cat dealer. Air flow restriction (system) is added to the existing restriction from the factory.
- <sup>2</sup> Generator temperature rise is based on a 40°C (104°F) ambient per NEMA MG1-32.
- # Operating Fuel Pressure is the fuel pressure required to be delivered at the genset base frame rail connection.

**STANDBY POWER:** Output available with varying load for the duration of the interruption of the normal source power. Average power output is 70% of the standby power rating. Typical operation is 200 hours per year, with maximum expected usage of 500 hours per year.

#### 1 CFH = 1000 BTU/HR

Fuel Rates are based on heat values of 1015 BTU/SCF for Natural Gas and 2500 BTU/SFC for Propane Vapor @77°F (25°C) and 328 ft (100m) above sea level.

Additional ratings may be available for specific customer requirements, contact your Cat representative for details.

Genset Ratings are based on ambient temperature of 77°F and elevation of 1200 ft above sea level.

For higher temperatures and elevations the following derate specifications are to be used: Altitude: Derate 3.0% per every 1000 ft (305m.) above 1200 ft (365 m.) Temperature: Derate 1.0% per 10°F (5.55°C) temperature above 77°F (25°C).

# LET'S DO THE WORK.™

[www.cat.com/electricpower](http://www.cat.com/electricpower)

©2023 Caterpillar  
All rights reserved.

Materials and specifications are subject to change without notice. The International System of Units (SI) is used in this publication. CAT, CATERPILLAR, LET'S DO THE WORK, their respective logos, "Caterpillar Corporate Yellow", the "Power Edge" and Cat "Modern Hex" trade dress as well as corporate and product identity used herein, are trademarks of Caterpillar and may not be used without permission.