

0.5 g/bhp-hr NOx or 1 g/bhp-hr NOx (NTE)

### CAT® ENGINE SPECIFICATIONS

#### V-20, 4-Stroke-Cycle

Bore	170 mm (6.7 in.)
Stroke	190 mm (7.5 in.)
Displacement	86.7 L (5288 cu. in.)
Aspiration	Turbocharged-2 Stage Aftercooled
Digital Engine Management	
Governor and Protection	Electronic (ADEM™ A3)
Combustion	Low Emission (Lean Burn)
Engine Weight	
net dry (approx)	11,168.4 kg (24,622 lb)
Power Density	8.7 kg/kW (14.3 lb/hp)
Power per Displacement	19.9 bhp/L
Total Cooling System Capacity	285.8 L (75.5 gal)
Jacket Water	268.8 L (71 gal)
Aftercooler Circuit	17 L (4.5 gal)
Lube Oil System (refill)	2063.1 L (545 gal)
Oil Change Interval	1000 hours
Rotation (from flywheel end)	Counterclockwise
Flywheel and Flywheel Housing	SAE No. 00
Flywheel Teeth	183

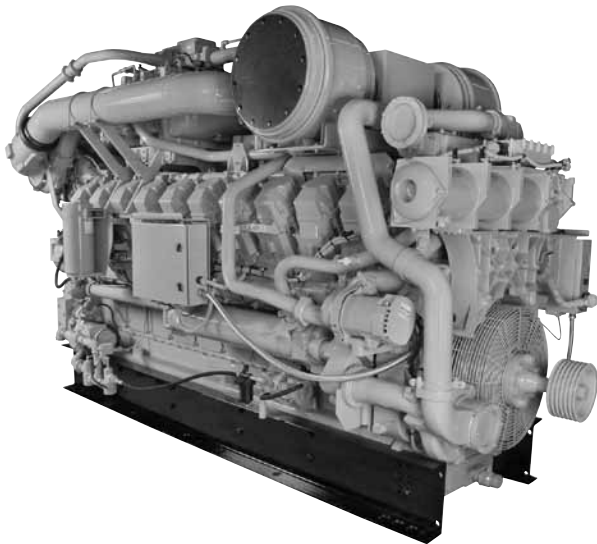

## FEATURES

### Engine Design

- Built on G3500 LE proven reliability and durability
- Ability to burn a wide spectrum of gaseous fuels
- Robust diesel strength design prolongs life and lowers owning and operating costs
- Broad operating speed range at lower site air densities (high altitude/hot ambient temperatures)
- Higher power density improves fleet management
- Quality engine diagnostics
- Detonation-sensitive timing control for individual cylinders

### Ultra Lean Burn Technology (ULB)

ULB technology uses an advanced control system, a better turbo match, improved air and fuel mixing, and a more sophisticated combustion recipe to provide:

- Lowest engine-out emissions
- Highest fuel efficiency
- Improved altitude and speed turndown
- Stable load acceptance and load rejection

### Emissions

- Meets U.S. EPA Spark Ignited Stationary NSPS emissions for 2010 and some non-attainment areas
- Lean air/fuel mixture provides best available emissions and fuel efficiency for engines of this bore size

### Advanced Digital Engine Management

ADEM A3 engine management system integrates speed control, air/fuel ratio control, and ignition/detonation controls into a complete engine management system. ADEM A3 has improved: user interface, display system, shutdown controls, and system diagnostics.

### Full Range of Attachments

Large variety of factory-installed engine attachments reduces packaging time.

### Testing

Every engine is full-load tested to ensure proper engine performance.

### Gas Engine Rating Pro

GERP is a PC-based program designed to provide site performance capabilities for Cat® natural gas engines for the gas compression industry. GERP provides engine data for your site's altitude, ambient temperature, fuel, engine coolant heat rejection, performance data, installation drawings, spec sheets, and pump curves.

### Product Support Offered Through Global Cat Dealer Network

More than 2,200 dealer outlets

Cat factory-trained dealer technicians service every aspect of your petroleum engine

Cat parts and labor warranty

Preventive maintenance agreements available for repair-before-failure options

S•O•S<sup>SM</sup> program matches your oil and coolant samples against Caterpillar set standards to determine:

- Internal engine component condition
- Presence of unwanted fluids
- Presence of combustion by-products
- Site-specific oil change interval

### Over 80 Years of Engine Manufacturing Experience

Over 60 years of natural gas engine production

Ownership of these manufacturing processes enables Caterpillar to produce high quality, dependable products

- Cast engine blocks, heads, cylinder liners, and flywheel housings
- Machine critical components
- Assemble complete engine

### Web Site

For all your petroleum power requirements, visit [www.catoilandgas.cat.com](http://www.catoilandgas.cat.com).

**STANDARD EQUIPMENT**

---

**Air Inlet System**

Axial Flow Air cleaner  
Cleanable  
Intermediate-duty with service indicator

**Control System**

ADEM A3 with integrated electronic throttle control  
CSA certified

**Cooling System**

Two-stage charge air cooling  
First Stage — JW + OC + 1st Stage AC  
Second Stage — 2nd Stage AC  
Thermostats and housing  
Engine-driven jacket and aftercooler water pump  
Stainless steel aftercooler cores

**Exhaust System**

Dry exhaust manifolds  
Dry exhaust elbow

**Flywheels and Flywheel Housings**

SAE No. 00 flywheel  
SAE No. 00 flywheel housing  
SAE standard rotation

**Fuel System**

7-50 psi gas supply  
Fuel system is sized for 800 to 1200 btu/scf  
(31.5 to 47.2 MJ/Nm<sup>3</sup>)

**Ignition System**

ADEM A3  
Outdoor CSA certified

**Lubrication System**

Crankcase breather — top mounted  
Oil cooler  
Oil filter — RH  
Oil pan — 144 gal  
Oil sampling valve  
Turbo oil accumulator

**Power Take-Offs**

Front housing — two-sided  
Front lower LH, RH, and upper RH accessory drives

**Torsional Vibration Analysis**

Provided through Caterpillar, required through Q1 2010

**General**

Paint — Cat yellow  
Crankshaft vibration damper and guard

**OPTIONAL EQUIPMENT**

---

**Air Inlet System**

Round air inlet adaptors

**Charging System**

Battery chargers  
CSA certified version available with  
Charging system  
CSA alternator (24V, 65A)

**Cooling System**

Mechanical joint assembly connections

**Exhaust System**

Flexible fittings  
Elbows  
Flanges

**Fuel System**

Gas filter

**Instrumentation**

Advisor display panel  
Communications module

**Lubrication System**

Lubricating oil  
Oil bypass filter  
Air prelube pump

**Power Take-Offs**

Front stub shaft  
Pulleys  
Double damper

**Starting System**

Air starting motor with controls (90 psi or 150 psi)  
Jacket water coolant heater  
Jacket water heater  
ASME/ANSI B16.3 compliant piping components

**General**

Special paint

**EU Certification**

EEC DOI certification

**Support**

Factory commissioning

**TECHNICAL DATA**
**G3520B Gas Petroleum Engine — 1400 rpm**

Fuel System		0.5 g NOx NTE Rating DM8750-03	1.0 g NOx NTE Rating DM8770-01
<b>Engine Power</b> @ 100% Load	bkW (bhp)	1286 (1725)	1286 (1725)
<b>Engine Speed</b>	rpm	<b>1400</b>	<b>1400</b>
Max Altitude @ Rated Torque and 38°C (100°F)	m (ft)	914.4 (3000)	1524.0 (5000)
Speed Turndown @ Max Altitude, Rated Torque, and 38°C (100°F)	%	25	25
<b>Aftercooler Temperature</b>			
Stage 1 (JW)	°C (°F)	98.9 (210)	98.9 (210)
Stage 2 (SCAC)	°C (°F)	54 (130)	54 (130)
<b>Emissions*</b>			
NOx	g/bkW-hr (g/bhp-hr)	0.67 (0.50)	1.34 (1.00)
CO	g/bkW-hr (g/bhp-hr)	2.98 (2.22)	3.49 (2.6)
CO <sub>2</sub>	g/bkW-hr (g/bhp-hr)	629 (469)	609 (454)
VOC**	g/bkW-hr (g/bhp-hr)	0.6 (0.45)	0.5 (0.37)
<b>Fuel Consumption***</b> @ 100% Load	MJ/bkW-hr (Btu/bhp-hr)	10.19 (7205)	9.76 (6895)
<b>Heat Balance</b>			
Heat Rejection to Jacket Water @ 100% Load			
JW	bkW (Btu/min)	534.05 (30,398)	497.16 (28,273)
OC	bkW (Btu/min)	97.68 (5560)	97.68 (5560)
Heat Rejection to Aftercooler @ 100% Load			
1st Stage AC	bkW (Btu/min)	120.9 (6876)	112.87 (6419)
2nd Stage AC	bkW (Btu/min)	185.9 (10,577)	198.8 (8462)
Heat Rejection to Exhaust @ 100% Load	bkW (Btu/min)	1342.49 (76,414)	1266.6 (72,030)
Heat Rejection to Atmosphere @ 100% Load	bkW (Btu/min)	128.81 (7332)	128.81 (7332)
<b>Exhaust System</b>			
Exhaust Gas Flow Rate @ 100% Load	m <sup>3</sup> /min (cfm)	317.57 (11,215)	300.2 (10,600)
Exhaust Stack Temperature @ 100% Load	°C (°F)	531.67 (989)	536 (997)
<b>Intake System</b>			
Air Inlet Flow Rate @ 100% Load	m <sup>3</sup> /min (scfm)	109.10 (3853)	102.45 (3618)
<b>Gas Pressure</b>	kPag (psig)	48-345 (7-50)	48-345 (7-50)

\*at 100% load and speed, all values are listed as not to exceed

\*\*Volatile organic compounds as defined in U.S. EPA 40 CFR 60, subpart JJJJ

\*\*\*ISO 3046/1

### G3520B — RIGHT SIDE VIEW & FRONT VIEW

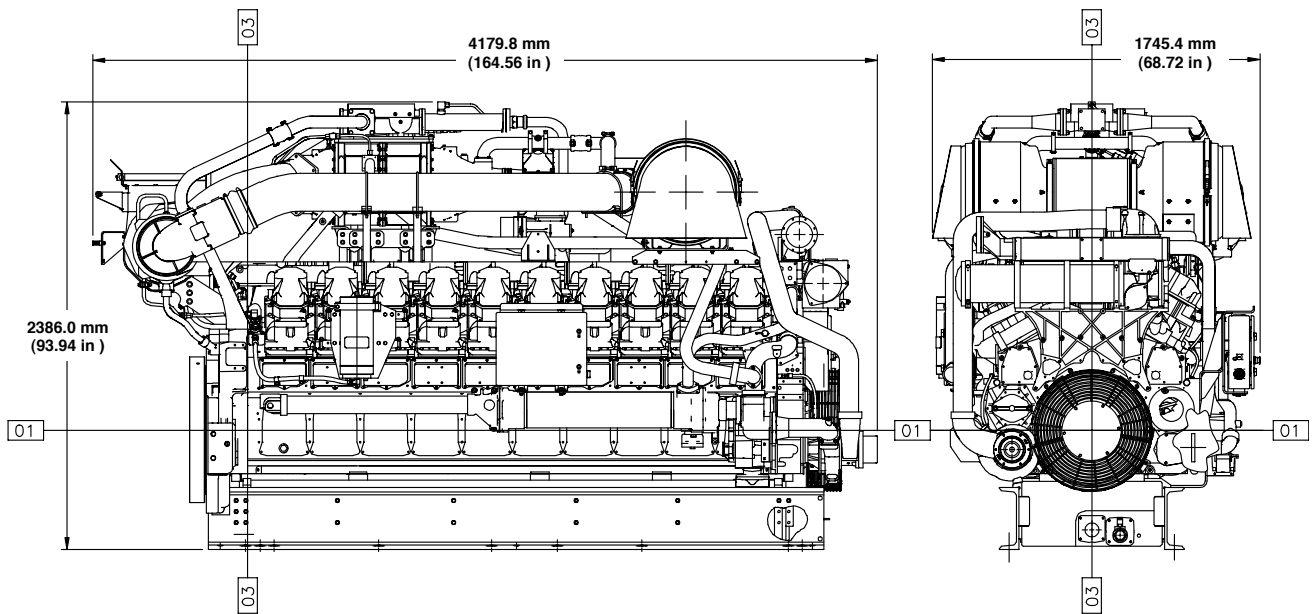

DIMENSIONS		
Length	mm (in)	4180.84 (164.6)
Width	mm (in)	1755.14 (69.1)
Height	mm (in)	2385.06 (93.9)
Shipping Weight	kg (lb)	11,168.4 (24,622)

**Note:** General configuration not to be used for installation. See general dimension drawing.

### RATING DEFINITIONS AND CONDITIONS

Engine performance is obtained in accordance with SAE J1995, ISO3046/1, BS5514/1, and DIN6271/1 standards.

Transient response data is acquired from an engine/generator combination at normal operating temperature and in accordance with ISO3046/1 standard ambient conditions. Also in accordance with SAE J1995, BS5514/1, and DIN6271/1 standard reference conditions.

**Conditions:** Power for gas engines is based on fuel having an LHV of 33.74 kJ/L (905 Btu/cu ft) at 101 kPa (29.91 in. Hg) and 15° C (59° F). Fuel rate is based on a cubic meter at 100 kPa (29.61 in. Hg) and 15.6° C (60.1° F). Air flow is based on a cubic foot at 100 kPa (29.61 in. Hg) and 25° C (77° F). Exhaust flow is based on a cubic foot at 100 kPa (29.61 in. Hg) and stack temperature.

Materials and specifications are subject to change without notice. The International System of Units (SI) is used in this publication. CAT, CATERPILLAR, their respective logos, ADEM, S-O-S, "Caterpillar Yellow" and the "Power Edge" trade dress, as well as corporate and product identity used herein, are trademarks of Caterpillar and may not be used without permission.