



C32 ACERT™ Petroleum Engine

597-828 bkW
(800-1110 bhp)
2100 rpm

**Water-Cooled Manifold
Hazardous Location**

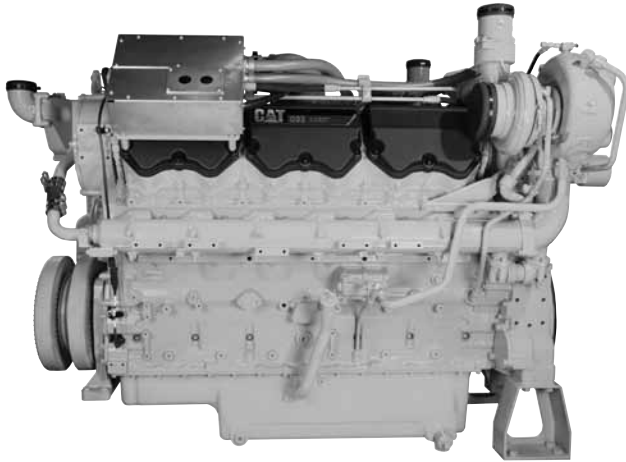

Image is a representation only, and may show optional attachments.

CAT® ENGINE SPECIFICATIONS

V-12, 4-Stroke-Cycle-Diesel

Emissions	U.S. Non-Road Tier 2 CARB, IMO Tier II, EPA Marine Tier 2
Peak Torque at Speed.....	2776 lb-ft
Bore	145 mm (5.7 in)
Stroke	162 mm (6.4 in)
Displacement.....	32.1 L (1960 cu. in)
Aspiration	Turbocharged-Aftercooled
Governor and Protection.....	Electronic (ADEM™ A4)
Engine Weight, net dry (approx)	3152 kg (6950 lb)
Capacity for Liquids	
Lube Oil System (refill)	71.2 L (18.8 gal)
Cooling System.....	54.5 L (14.4 gal)
Oil Change Interval.....	250 hours
Rotation (from flywheel end)	Counterclockwise
Flywheel and Flywheel Housing ...	SAE No. 0 or SAE No. 1
Flywheel Teeth	136

FEATURES

Engine Design

- Proven reliability and durability
- 45°C ambient capability*
- Robust diesel strength design prolongs life and lowers owning and operating costs
- Broad operating speed range
- PTO drive options provide flexible access to auxiliary power for pumps and other needs

Cat® Hazardous Location Engine

Cat Petroleum Hazardous Location Engines are third-party certified from Caterpillar

- Class I Division 2 (NEC 500)
- Class I Zone 2 (NEC 505)
- ATEX Directive (94/9/EC) Group II, 3G environments (Zone 2) with Gas Group IIA, Electrical IIC, and Temperature Class T3**

Technology

- Electrical harness containing point-to-point wiring without splices in any power/signal wires
- Electrical harnesses and connectors are overmolded and are routed through urethane tube for protection against impact and vertical flame propagation.
- To meet safety requirements, connectors require the use of a special tool to be disconnected and bear the “do not disconnect while energized” warning.
- Optional ATEX and NEC certified 25-foot customer harness
- ECU is certified as part of the engine to restricted breathing per EN 60079-15. ECU is protected with a stainless steel guard.
- Fuel injector connections at valve cover bases are protected with stainless steel guards

Advanced Digital Engine Management

ADEM A4 engine management system integrates speed control, air/fuel ratio control and ignition/detonation controls into a complete engine management system with integrated digital ignition, engine protection and monitoring.

*See TMI for altitude and ambient capability

**ATEX compliant with exceptions — packager responsible to ensure ATEX compliant installation

Transmissions

The full line of Cat engine/transmission packages can be fully integrated with your axle, hydraulics, and operator interface. Cat transmissions deliver continuous operation under full load, smooth shifting at any speed, and maximum up time, with unmatched durability and easy maintenance.

Custom Packaging

Trust a Cat factory custom package to meet your exact petroleum application needs. Cat engines, generators, enclosures, controls, radiators, transmissions — anything your project requires — can be custom designed and matched to create a one-of-a kind solution. Custom packages are globally supported and are covered by a one-year warranty after startup.

Full Range of Attachments

Large variety of factory-installed engine attachments reduces packaging time

Testing

Every engine is full-load tested to ensure proper engine performance.

Product Support Offered Through Global Cat Dealer Network

More than 2,200 dealer outlets

Cat factory-trained dealer technicians service every aspect of your petroleum engine

Cat parts and labor warranty

Preventive maintenance agreements available for repair-before-failure options

S•O•SSM program matches your oil and coolant samples against Caterpillar set standards

Over 80 Years of Engine Manufacturing Experience

Ownership of these manufacturing processes enables Caterpillar to produce high quality, dependable products.

- Cast engine blocks, heads, cylinder liners, and flywheel housings
- Machine critical components
- Assemble complete engine

Web Site

For all your petroleum power requirements, visit www.catoilandgas.cat.com.



STANDARD EQUIPMENT

Air Inlet System

Dual side-mounted turbochargers — inlet 152.4 mm (6 in) hose connection

Control System

Programmable ratings
Cold mode start strategy
Automatic altitude compensation
Power compensation for fuel temperature
Programmable low and high idle
Electronic diagnostics and fault logging
Engine monitoring and protection system (speed, temperature, pressure).
J1939 Broadcast (diagnostic, engine status and control)
Electronic governing, PTO speed control
Certified electrical control system
Customer interface harness available as optional attachment

Cooling System

Thermostats and housing — outlet LH vertical orientation
Jacket water pump — gear-driven, centrifugal, RH

Exhaust System

Exhaust manifold, water-cooled
Dual turbo, rear turbo exhaust, full marmon connection
127 mm (5 in), maximum load 10 kg for direct connection to turbo
Water-cooled center sections

Flywheels and Flywheel Housing

Mandatory selection of:
SAE No. 0 or SAE No. 1 flywheel and housing
SAE standard rotation

Fuel System

MEUI fuel system
Fuel filter — RH (2 micron high performance)
Fuel transfer pump
Fuel priming pump

Lube System

Crankcase breather — rear-mounted
Oil cooler — RH
Oil filler in RH front gear case
Oil filter — RH
Oil level gauge — RH
Oil pan rear sump

Mounting System

Narrow front support

Power Take-Offs

Crankshaft pulley — 203.2 mm (8 in) 5 grooves 15.9 (.63 in) wide; 292.1 mm (11.5 in) 1 groove 15.9 (.63 in) wide

General

Paint — Cat yellow
Vibration damper with single pulley
Lifting eyes
Automatic variable timing — electronic
Electronic installation kit 70-pin connector (connectors, pins, socket)

Mandatory Options

HP must be specified when ordering
All engines shipped at 2100 rpm
Flywheel housing

These engines meet the current IMO emission standards as defined by Regulation 13 of Annex VI to the International Convention for the Prevention of Pollution from Ships, 1973, as modified by the Protocol of 1978, further amended by the Protocol of 1997.

A statement of compliance issued by the United States government's EPA (Environmental Protection Agency) is included in the technical file that is shipped with the engine as proof of our engine's ability to meet IMO emissions requirements. If this technical file is insufficient to meet the customer's requirements, then a GL or CCS IMO emissions certification may be ordered.

OPTIONAL ATTACHMENTS

Air Compressor**Air Inlet System**

Air cleaner
Air inlet adapters
Turbocharger outlet adapters
Air lines

Charging System

Battery chargers
Charging alternators
Alternator mounting
Circuit breakers and mountings

Cooling System

Dry charge coolant conditioners
Thermostat housing
Coolant level sensor
Radiator
Suction fans and blower fans
Fan adapters
Fan drives

Emissions

IMO certifications

Exhaust System

Elbows
Mufflers

Fuel Systems

Electric fuel priming pump

Instrumentation

Customer management device
Interconnect harness
Gauges and instrument panels

Lube System

Oil pans
Oil service side
Oil level gauge
Oil filters
Lubricating oils

Mounting System

Structural steel base
Engine support — front and rear

Power Take-Offs

Auxiliary drive
Damper pulley
Hydraulics gear pumps

Protection System

Mechanical shutoffs
Solenoid shutoffs

Starting System

Electric starting motors — 12V, 24V
Battery sets — 24V
Battery rack and cable
Starting aids

Transmission Arrangement

Transmission water lines
Transmission cooler



PERFORMANCE CURVES

Turbocharged-Aftercooled

Well Service Rating — 746 bkW (1000 bhp) @ 2100 rpm*

DM9686-01

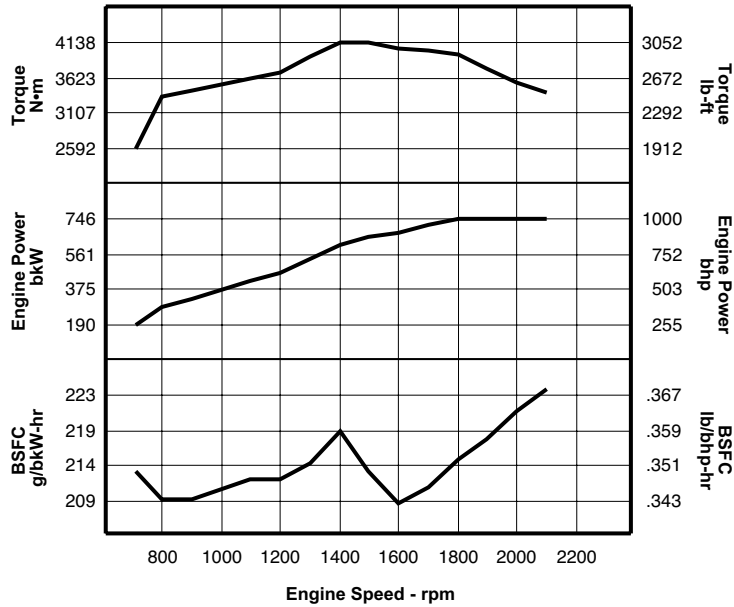

Heat Rejection Data										
Engine Speed rpm	Engine Power		Rej to JW		Rej to Atmos		Rej to Exh		From Aft Clr	
	bkW	bhp	bkW	Btu/min	bkW	Btu/min	bkW	Btu/min	bkW	Btu/min
2100	746.0	1000.4	512	29117	128	7279	569	32359	167	9497
1900	746.0	1000.4	496	28207	130	7393	561	31904	160	9099
1700	716.0	960.2	452	25705	113	6426	508	28890	136	7734
1500	650.0	871.7	426	24227	112	6369	461	26217	108	6142
1300	535.0	717.4	381	21667	95	5403	383	21781	60	3412
1100	417.0	559.2	309	17573	77	4379	301	17118	23	1308
800	280.0	375.5	185	10521	43	2445	236	13421	7	398

*Other engine ratings are available. Please contact dealer for performance data.



PETROLEUM ENGINE

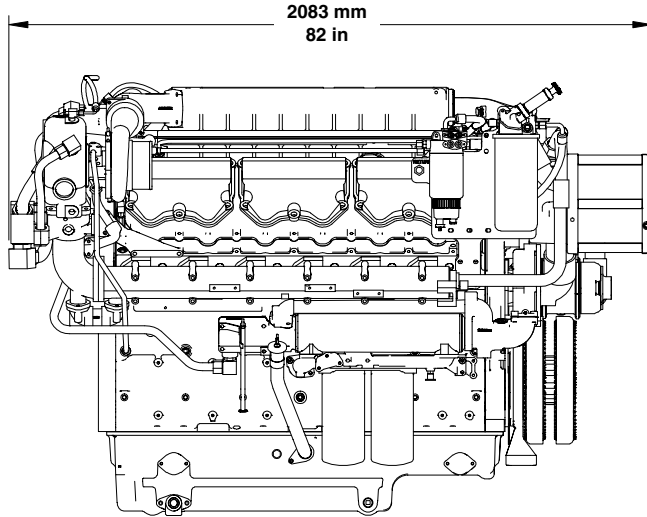

Right Side View

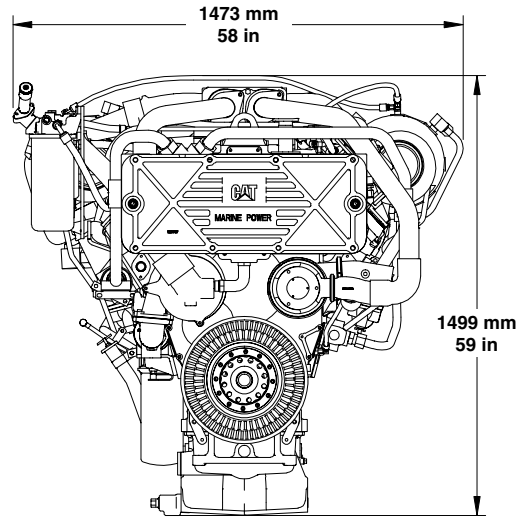

Front View

Engine Dimensions		
Length	2083 mm	82 in
Width	1473 mm	58 in
Height	1499 mm	59 in
Engine Weight (dry)	3152 kg	6950 lb

Note: Do not use for installation design. See general dimension drawings for detail (Drawing #310-1652).

RATING DEFINITIONS AND CONDITIONS

Engine Performance is corrected to inlet air standard conditions of 99 kPa (29.31 in Hg) dry barometer and 25°C (77°F) temperature. These values correspond to the standard atmospheric pressure and temperature as shown in SAE J1995.

Performance measured using a standard fuel with fuel gravity of 35 degrees API having a lower heating value of 42,780 kJ/kg (18,390 BTU/lb) when used at 29°C (84.2°F) where the density is 838.9 g/L (7.001 lb/U.S. gal).

The corrected performance values shown for Cat engines will approximate the values obtained when the observed performance data is corrected to SAE J1995, ISO 3046-2, ISO 8665, ISO 2288, ISO 9249, ISO 1585, EEC 80/1269, and DIN 70020 standard reference conditions.

Information contained in this publication may be considered confidential. Discretion is recommended when distributing. Materials and specifications are subject to change without notice. The International System of Units (SI) is used in this publication. CAT, CATERPILLAR, their respective logos, ACERT, ADEM, S•O•S, "Caterpillar Yellow" and the "Power Edge" trade dress, as well as corporate and product identity used herein, are trademarks of Caterpillar and may not be used without permission.