

9CM32C

Offshore Production Generating Set

4,360 kW_e (5,450 kVA) • 50/60 Hz @ 600 rpm

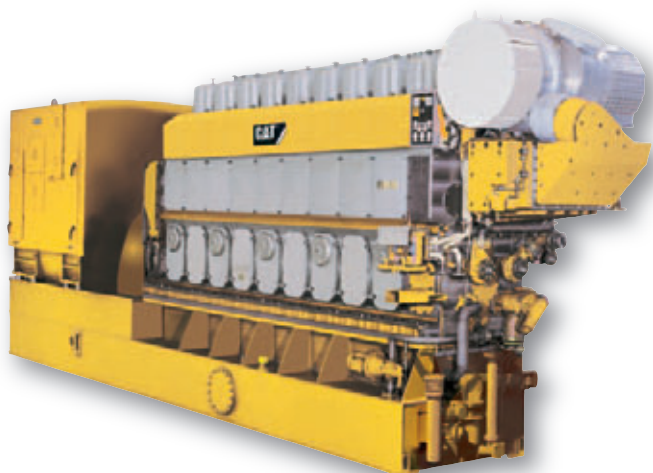

Engine Specifications

9CM32C, 4-Stroke-Cycle-Diesel

Emissions	IMO Tier II
Bore	320 mm (12.60 in.)
Stroke	480 mm (18.90 in.)
Displacement	347 L (21,200 in ³)
Aspiration	Turbocharged-Aftercooled
Governor	Electronic
Rated Speed	
60 Hz	600 rpm
50 Hz	600 rpm
Genset Weight, net dry (approx)	98 t (216,049 lbs)
Rotation (from flywheel)	Counterclockwise
System Capacity	
Cooling System	1,600 l (423 gal)
Lube Oil System (refill)	
4,500 kW	4,950 l (1,308 gal)

Features

Engine Design

- World-class reliability and durability – Incorporates years of proven component reliability and durability in marine industry
- Medium speed long-stroke engine design
- Ideal configuration for dynamically positioned semi-submersible rigs and drillships
- Compact cylinder head design
- Nodular cast-iron block with integrated ducts for lubricating oil and charge air
- Segmental camshaft design
- 25° tilt capability in all directions
- Engine design based on the higher requirements of heavy fuel oil
- High efficiency turbocharger
- Cylinder liner, only cooled outside the engine block
- Engine control terminal with analog instrumentation in robust cast casing
- Connecting rod, split off design
- Compact module for lower valve drives and injection pump drives with cam followers
- Optional Flexible Camshaft Technology (FCT)

Ease of Installation

- Standard modular design allows for ease of installation and reduced complexity
- Installation-friendly, due to pumps and filters installed on the engine
- Cooling water system with simple plug-in connections
- Full range of factory-installed engine attachments allows customization and reduction in installation time

Packaging Concept

- Assembled, tested, and validated as a package to minimize package vibration and maximize component life

Improved Serviceability

- Large inspection openings allow for convenient access to core engine internals for easier serviceability
- Core engine components designed for reconditioning and reuse at overhaul
- Worldwide dealer network with factory-trained technicians means that parts and support are never out of reach
- Simplified parts spectrum by using single-pipe exhaust gas ducting

Web Site

For all your petroleum power requirements, visit www.catoilandgasinfo.com



9CM32C Offshore Production Generating Set 4,360 kW_e (5,450 kVA)

Engine

- Motor-driven barring gear, fitted on engine
- Reversing contractor and pushbutton switch with cable
- Electronic speed setting equipment with actuator and speed pick-up
- Emergency shutdown equipment with pushbutton, separate, for manual emergency stop

Engine Indicators

- Gauge board with set liquid damped pressure gauges for: fuel, lubricating oil, fresh water, starting air, and charge air.
- On-engine thermometers for fuel, lubricating oil, fresh water, and charge air
- Electric remote speed indicator
- Turbocharger and remote speed indicator
- Exhaust gas temperature indicator

Control

- Manual control on engine, including: control panel with start/stop key, speed setting device, mechanical shutdown device, change over of control functions from engine to remote control
- Starting solenoid valve on engine, 24 V DC
- Separate electronic speed governor

Monitoring for Unattended Operation

Pressure switches, mounted on engine, for:

- Lube oil pressure at full load below danger level
- Low lube oil pressure
- Lube oil pressure below danger level
- Lube oil pressure prelubrication failed
- Low fresh water pressure at engine inlet
- Fresh water pressure at engine inlet below danger level
- Low fresh water pressure in LT circuit
- Low starting air pressure
- Low control air pressure engine/shutdown air pressure
- Low fuel pressure at engine inlet

Switches for:

- High lube oil temperature at engine inlet
- Lube oil temperature at engine inlet above danger level
- High water temperature at engine inlet
- Water temperature at engine outlet above danger level
- High charge-air temperature at engine inlet
- Detection of water in charge-air duct
- Leak fuel level
- Alarm contact for high differential pressure at fuel filter
- Alarm contact for high differential pressure at lube oil back flushing filter
- Set of thermocouples after each cylinder, before and after turbocharger
- Crankcase oil mist detector

Control Cabinet with housings for wall mounting, including:

- Protection equipment designed for automatic and manual stop input signals, starting interlock input signals, monitoring for the wire break of the input signal units and the emergency shutdown solenoid
- Speed recording system for overspeed, firing speed and minimum speed
- Start/stop logic, controlled by engine automatic start (optional)
- Service hour counter
- Noris alarm system, cassette type, designed for alarm inputs for the engine including exhaust mean-value monitoring equipment as well as alarm inputs for the propulsion plant
- Group alarm panel for the bridge and with optional and acoustical alarm equipment

Starting Air System

- Separate non-return valve for the starting air pipe to the engine

Air Intake System

- Air intake filter, fitted on the turbocharger
- Air bottles, separate

Diesel Oil System

- Separate circulating pump driven by electric motor, horizontal or vertical
- Duplex filter with differential pressure indication

Exhaust System

- Turbocharger at free end with transition nozzle (0 degrees from the vertical and away from engine), with compressor cleaning device
- Expansion joint separate
- Separate silencer and spark arrester, unlagged 35 dB(A)

Fresh Cooling Water System

- HT pump, fitted on engine
- LT pump, separate, vertical design, electric motor driven
- HT thermostat, not powered and separate
- Engine preheating equipment, fitted on base frame

Lubricating Oil System

- Plate cooler, fitted on engine
- Force pump, fitted on engine
- Prelubrication pump, fitted on base frame, electric motor driven
- Boll and Kirch automatic backflushing filter, separate
- Duplex filter with differential pressure indication, separate
- Pressure control valve, separate
- Thermostat, not powered, separate

Connecting Parts – Engine

- Set of connecting parts between flange coupling and flywheel
- Flexible flange coupling between engine and generator
- Base frame with flywheel guard and incorporating lube oil sump tank, for engine and generator
- Mounting of engine and generator on the base frame
- Set of bonded rubber rails for resilient mounting of the base frame
- Set of flexible pipe connections

Tools

- Set of tools for the engine including hydraulic tightening tools and nozzle tester
- Set of tools for turbocharger
- Inside micrometer for cylinder liners
- Ruler for cylinder liner

Spare Parts

- Set of engine spare parts for unrestricted operation
- Set of spare flexible pipe connections



Technical Data 9CM32C Offshore Production Generating Set

	50/60 Hz
Engine Power	4,500 kW (6,035 bhp)
Generator Set Rating*	4,360 kWe (5,450 kVA)
BMEP @ Rated	25.9 bar (375.6 psi)
BSFC @ Rated	177 g/kWh (0.291 lbs/bhp-hr)
Maximum Allowable Fuel Temperature to Engine (MDO)	20°C (68°F)
Air Demand Based on 20°C Inlet Temperature and 101.3 kPa Inlet Pressure	26,250 m ³ /h (15,450 cfm)
Maximum Allowable Air Temperature to Air Filters	45°C (113°F)
Exhaust Flow Based on 310°C Stack Temperature and 105 kPa Stack Pressure	32,445 kg/h (71,529 lbs/hr)
Maximum Allowable Backpressure	3 kPa (12 in. H ₂ O)
LT SCAC Heat Rejection	505 kW (28,719 Btu/min)
HT SCAC Heat Rejection	1,705 kW (96,962 Btu/min)
Maximum Charge Air Cooler (LT-stage) Inlet Temperature	38°C (100°F)
JW Heat Rejection	625 kW (35,543 Btu/min)
Radiative Convective Heat Rejection	210 kW (11,942 Btu/min)

* Assumes 97% efficiency and a power factor of 0.8

Note: Do not use for installation design. See general dimension drawings for detail.

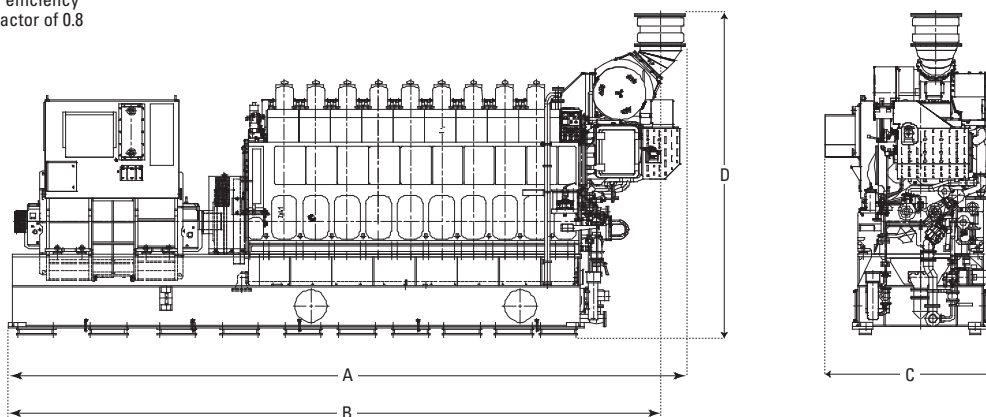

Package Dimensions

Length (A)	11,419 mm	449.57 in.
Length (B)	10,991 mm	432.72 in.
Width (C)	2,611 mm	102.80 in.
Height (D)	5,413 mm	213.110 in.
Package Weight (dry)*	98 t	216,049 lb

* Dependent on generator type

Rating Definitions and Conditions

Engine Performance is corrected to inlet air standard conditions of 99 kPa (29.31 in. Hg) dry barometer and 25°C (77°F) temperature. These values correspond to the standard atmospheric pressure and temperature as shown in SAE J1995.

Performance measured using a standard fuel with fuel gravity of 35 degrees API having a lower heating value of 42,780 kJ/kg (18,390 BTU/lb) when used at 29°C (84.2°F) where the density is 838.9 g/L (7.001 lb/U.S. gal).

The corrected performance values shown for Cat® engines will approximate the values obtained when the observed performance data is corrected to SAE J1995, ISO 3046-2, ISO 8665, ISO 2288, ISO 9249, ISO 1585, EEC 80/1269, and DIN 70020 standard reference conditions.



Caterpillar Global Petroleum

Headquarters

Caterpillar Inc.

Global Petroleum
13105 N.W. Freeway
Suite 1100
Houston, Texas 77040-6321
Phone: (+1) 713-329-2207
Telefax: (+1) 713-895-4280

Europe, Africa, Middle East and CIS

Caterpillar Commercial Northern Europe Ltd.

Global Petroleum
OTV House
Wokingham Road, Rounds Hill
Bracknell, Berkshire
United Kingdom, RG42 1 NG
Phone: (+44) 1344 782 920
Telefax: (+44) 1344 782 930

Caterpillar Motoren GmbH & Co. KG

Global Petroleum
Falckensteiner Str. 2
D-24159 Kiel, Germany
Phone: (+49) 431 3995 2208
Telefax: (+49) 431 3995 4208

Caterpillar CIS LLC

R82 Sadovnicheskaya Str.
Moscow 113035, RF
Phone: (+7-495) 755 6811
Telefax: (+7-495) 785 5688

Asia Pacific

Caterpillar China Investment Co., Ltd.

Global Petroleum
Room 1801 Caterpillar Tower
No. 8 Wangjing Street
Beijing 100102, P.R. China
Phone: (+86-10) 5921 0521
Telefax: (+86-10) 5921 0022

Caterpillar Asia Pte., Ltd.

Global Petroleum
14 Tractor Road
Singapore 627973
Phone: (+65) 6828 7333
Telefax: (+65) 6828 7414

For more information please visit our website:
www.catoilandgasinfo.com

Subject to change without notice.
Leaflet No. 714 GP · 04.12 · e · L+S · VM3
LEPW0044-00

© 2012 Caterpillar All Rights Reserved. Printed in Germany. CAT, CATERPILLAR, their respective logos, ACERT, ADEM, „Caterpillar Yellow“ and the POWER EDGE trade dress, as well as corporate identity used herein, are trademarks of Caterpillar and may not be used without permission



Caterpillar Global Petroleum is committed to sustainability. This document is printed on PEFC certificated paper.

