

DR2500

Hybrid Long Duration Resource Adequacy

OVERVIEW:

The basis of the DR2500 hybrid system is a Battery Energy Storage System (BESS) paired with the highly efficient (9100 BTU/Kwhr HHV), proven Caterpillar G3520H genset. The entire system is tied together through Caterpillar's Master Microgrid Controller and is ready to accept renewable natural gas.

This system cost-effectively provides best-in-class resiliency, long duration resource adequacy (weeks not hours) and emissions free spinning reserve – all at a very impressive power density of 5MW per ¼ acre.

The product offering has been jointly developed by Cupertino Electric, Inc. (CEI) and Peterson Power Systems (PPS). Both PPS and CEI are leaders in the energy space. We are also leaders in providing highly reliable, mission critical power to the data center industry.

Many of the design concepts incorporated into this hybrid system have roots in the data-center industry, a sector that requires lightning-fast deliveries and construction schedules, exceedingly high power densities (kW per square foot) and reliability in excess of what can be provided by a classic utility model.

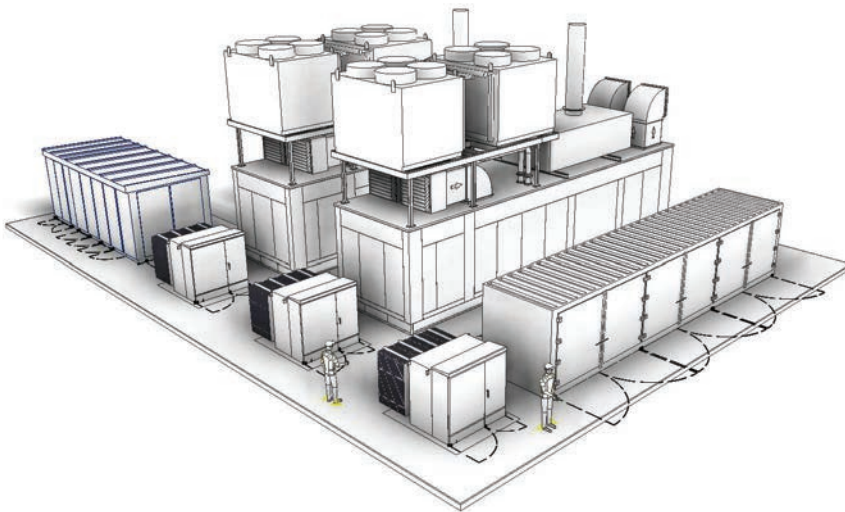

Product Components:

- Containerized battery storage scalable in 2.5MWH increments
- 12kv metal clad switchgear built to IOU standards including CAISO meter compatibility
- 2.5 MW Caterpillar G3520H natural gas reciprocating engine
- BACT emissions controls rated for continuous operation
- Caterpillar Microgrid Master Controller
- Step-up transformers

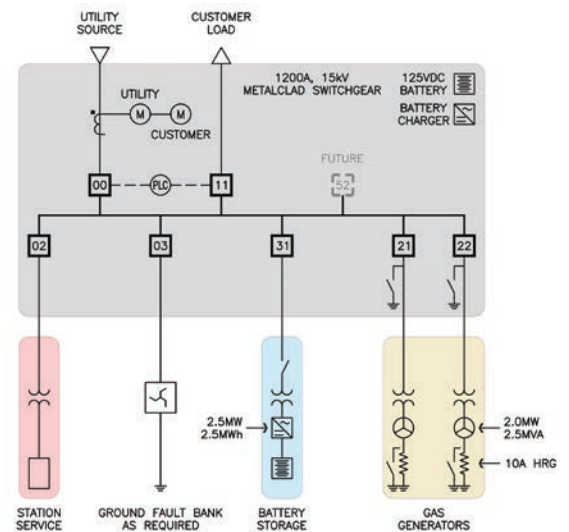

Talk to us about incorporating this technology into your system planning or, better yet, deploying it today.

Greg Lamberg

Utility Business Development Manager | Peterson Power Systems
galamberg@petersonpower.com | 510-292-3151

www.petersonpower.com/utilities

PETERSON



THE DR2500 HYBRID SOLUTION:

The DR2500 has evolved from the product offering developed specifically for substation islanding during public safety power shutoffs. Data center design concepts capable of hyperscale project deliveries are at the core of its design. In addition to a best-in-class long duration resource adequacy resource, the DR2500 is fully capable of functioning as a standalone microgrid.

Capabilities include:

- Long duration resource adequacy (weeks, not hours)
- Highly efficient - 9100 BTU/Kwhr HHV
- Resiliency with increased reliability
- Immediate response times (measured in milliseconds)
- Emissions-free spinning reserves
- Voltage support
- Islanding/microgrid capabilities

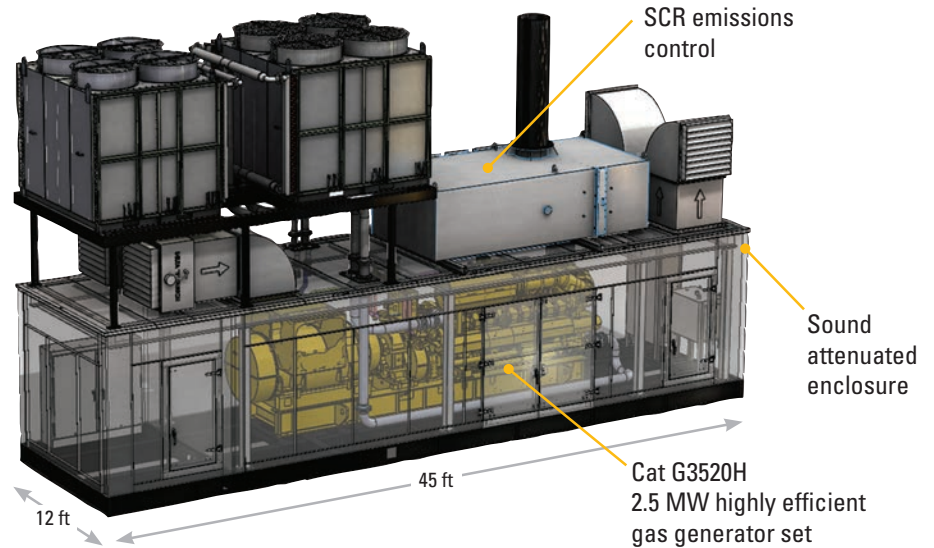

With increasing capacity and ramping needs throughout the Western United States, the need for long duration resource adequacy is becoming more and more apparent. Amplifying this need is the fact that recent utility and CCA procurements have focused on battery energy storage, which has duration of four hours or less. Long duration, on demand resource adequacy is needed now.

While we are starting to see solicitations for long duration storage (eight hours or longer) it will be some time before long duration storage is deployable on a large, distributed scale. The DR2500 is the perfect transitional technology to carry the grid and maintain reliability through the transition to a carbon-neutral future. Additionally, PSPS events and other emergencies are making microgrid-enabled systems like the DR2500 more and more valuable.

The DR2500 allows load-serving entities to address today's needs with an environmentally responsible 2.5MW building block that is ready to accept renewable natural gas. This best-in-class solution is cost effective, highly efficient and highly flexible. And, it can reach commercial operation in less than one year from the receipt of an order.